

X8-G2 动力套技术参数

动力套参数 All-in-One Thrust System Specification

产品型号	CM-X8-G2	最大拉力	17.5 kg (海平面高度)
Model		Max Thrust	17.5 kg (Sea level)
单轴推荐拉力	5-7.5 kg (海平面高度)	推荐拉力力效	9.7-8.4 g/W
Recommended takeoff weight per axis	5-7.5kg (Sea level)	Efficiency of recommended takeoff weight	
适配锂电池	12S-14S (LiPo)	额定电压	14S-54V / 12S-46V
Compatible lithium battery		Rated voltage	
电压范围	18-63 V	适用碳管直径	D35 / D40mm
Input voltage		Tube outer diameter	
动力套重量 (含线、桨)	1095 g*	线材规格	电源线: 14AWG 905 mm* 信号线: 915 mm*
Weight (with cable and propeller)		Cable specification	Power cable: 14AWG 905 mm* Signal cable: 915 mm*
适用环境温度	-20~50°C	防尘防水等级	IPX6
Operating temperature		Ingress Protection	
额定输入功率	920 W	额定输出功率	810 W
Rated power input		Rated power output	
线序	黑-GND, 白-PWM; 黄-GND, 灰-CH, 绿-CL		
Pinout	Black-GND, White-PWM & Yellow-GND, Gray-CH, Green-CL		

电调技术参数 ESC Specification

产品型号	80A-FOC	通讯方式	Cyphal (UAVCAN)
Model		Communication protocol	
最大电流	80A (3s)	持续电流	20 A
Peak current (3s)		Continuous current	
油门行程校准	不支持	双油门	PWM+CAN
Throttle range calibration	Not supported	Throttle Source	
PWM脉宽	1050-1950 μs	故障存储+日志	支持
Operating pulse width		Fault storage & Log	Supported

电机技术参数 Motor Specification

产品型号	8120-100KV	槽极数	36N40P
Model		Slot & Pole	
定子尺寸	81*20 mm	电机外直径	88.6 mm
Stator diameter		Motor diameter	

桨叶参数 Propeller Specification

30*11"S 高速桨 (默认)

30*11"S High speed propeller (Default)

产品型号	30*11"S (折叠桨)	总重量	193g*
Model	30*11"S (Folding propeller)	Total Weight	
主要材质	碳塑	单片桨叶重量	54.5g*
Material of blades	Carbon fiber reinforced plastics	Single blade weight	

30*11"桨 (选配)

30*11" Normal propeller (Optional)

产品型号	30*11" (折叠桨)	总重量	188g*
Model	30*11" (Folding propeller)	Total Weight	
主要材质	碳纤维增强尼龙复合材料	单片桨叶重量	51.6g*
Material of blades	Carbon fibre-reinforced nylon composite material	Single blade weight	

*存在误差, 以实物为准。本产品有两款桨叶可选, 主30*11"S 高速桨叶。

Subject to the actual product. Two types of propellers available, 30*11"S high speed propeller is mainly used.

负载性能参数 (46V) Load Performance Parameters (46V)

曲线图 Graph

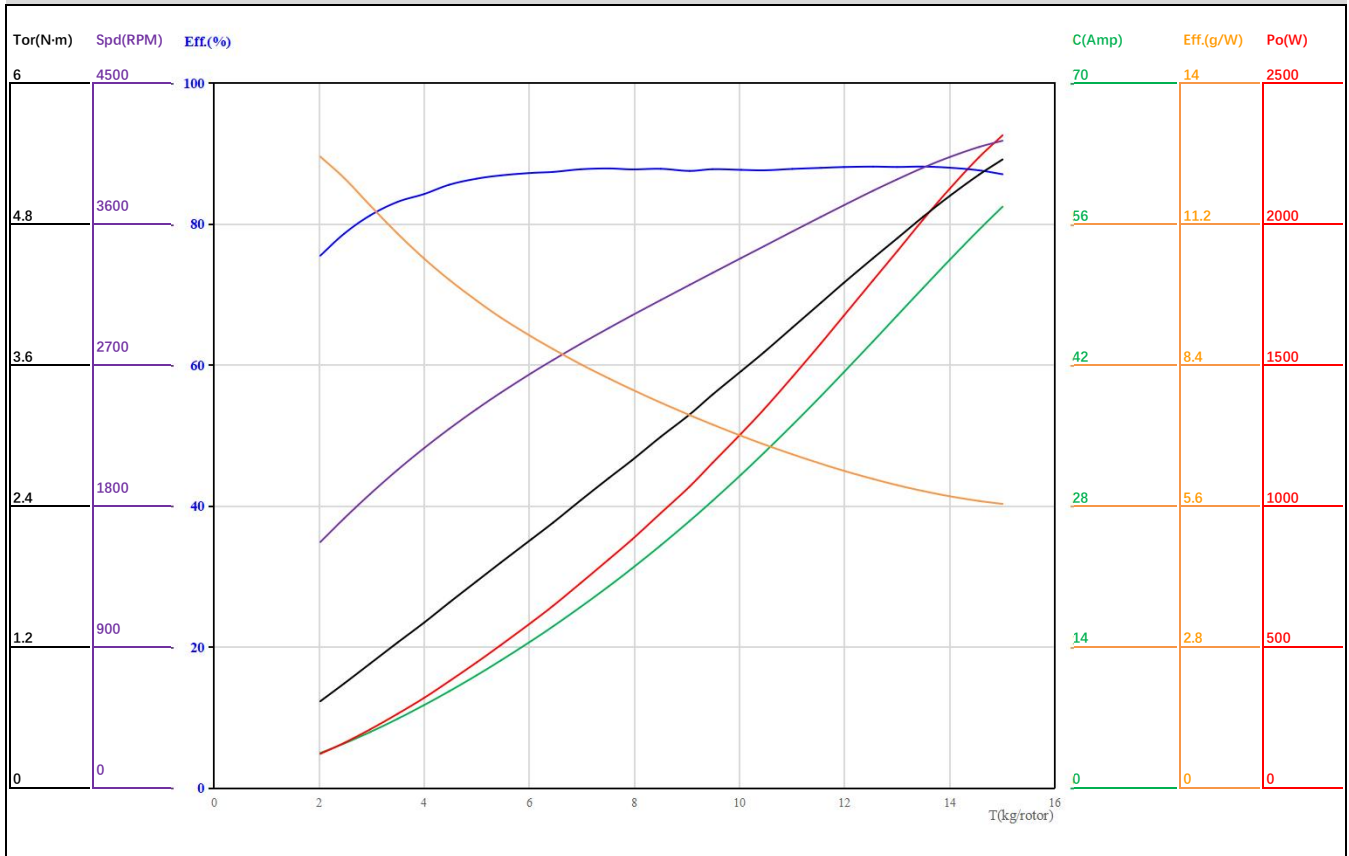

拉力数据表 Thrust Test Data

Voltage(V) 工作电压	Propeller 螺旋桨	Throttle(%) 油门	Thrust(g) 拉力	Current(A) 电流	Power Input(W) 输入功率	Speed(RPM) 转速	Efficiency(g/W) 力效	Torque (N·m) 扭矩	Power Output(W) 输出功率	Temperature(°C) 电机温度
46V (12S LiPo)	30*11"-S /30*11"	35%	2021	3.5	161.2	1571	12.5	0.74	121.7	/
		39%	2472	4.4	204.0	1721	12.1	0.89	160.4	
		42%	2968	5.6	256.5	1877	11.6	1.06	208.3	
		45%	3493	6.9	317.3	2032	11.0	1.24	263.8	
		48%	3999	8.3	380.4	2171	10.5	1.41	320.5	
		51%	4476	9.6	443.5	2294	10.1	1.58	379.5	
		54%	4994	11.2	515.8	2419	9.7	1.76	445.8	
		57%	5456	12.7	583.9	2524	9.3	1.92	507.4	
		60%	6043	14.6	674.2	2650	9.0	2.12	588.3	
		63%	6452	16.1	740.0	2733	8.7	2.26	646.8	
		66%	6977	18.0	828.9	2836	8.4	2.45	727.6	
		69%	7951	21.8	1004.4	3017	7.9	2.79	881.4	
		72%	8500	24.1	1110.3	3115	7.7	2.99	975.3	
		75%	9050	26.5	1221.7	3212	7.4	3.18	1069.5	
		78%	10034	31.2	1434.5	3384	7.0	3.55	1257.9	
		81%	10467	33.3	1533.5	3459	6.8	3.71	1343.8	
		84%	11007	36.1	1660.6	3553	6.6	3.92	1458.4	
		87%	11548	38.9	1792.3	3646	6.4	4.13	1576.8	
90%	12542	44.4	2042.8	3813	6.1	4.51	1800.7			
93%	13004	46.9	2161.6	3886	6.0	4.68	1904.3			
100%	15006	57.7	2658.5	4132	5.6	5.35	2314.8			

以上数据为好盈实验室于室温 25°C、海平面高度，变化油门输入调节测得。两款桨叶拉力数据相同。

The above data was measured by HOBBYWING Laboratory at room temperature 25°C, at sea level, with varying throttle input adjustments. The test data of two types of propellers are the same.

负载性能参数 (54V) Load Performance Parameters (54V)

曲线图 Graph

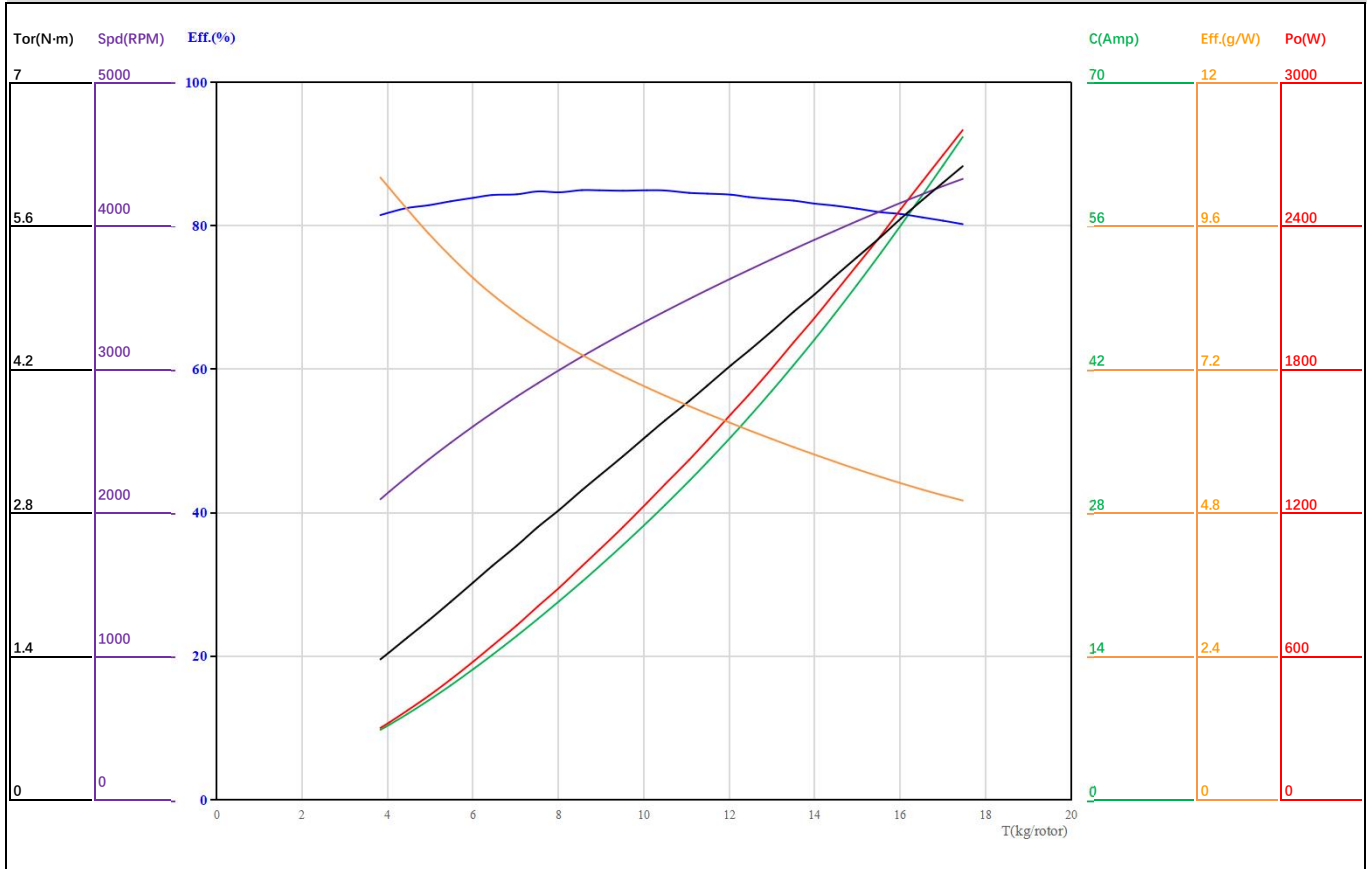

拉力数据表 Thrust Test Data

Voltage(V) 工作电压	Propeller 螺旋桨	Throttle(%) 油门	Thrust(g) 拉力	Current(A) 电流	Power Input(W) 输入功率	Speed(RPM) 转速	Efficiency(g/W) 力效	Torque (N-m) 扭矩	Power Output(W) 输出功率	Temperature(°C) 电机温度
54V (14S LiPo)	30*11"-S /30*11"	35%	4459	8.4	451.4	2250	9.9	1.58	372.3	/
		39%	4965	9.7	524.4	2371	9.5	1.75	434.5	
		42%	6007	12.7	688.6	2602	8.7	2.12	577.6	
		45%	6450	14.1	763.2	2694	8.5	2.28	643.2	
		48%	7031	16.0	864.8	2810	8.1	2.48	729.7	
		51%	8026	19.4	1048.4	2995	7.7	2.83	887.5	
		54%	8552	21.3	1149.4	3088	7.4	3.02	976.5	
		57%	9509	24.8	1342.4	3248	7.1	3.35	1139.4	
		60%	10495	28.7	1552.8	3403	6.8	3.70	1318.4	
		63%	11062	31.1	1680.3	3489	6.6	3.89	1421.2	
		66%	12045	35.4	1912.8	3633	6.3	4.24	1613.0	
		69%	12992	39.9	2152.8	3766	6.0	4.57	1802.2	
		72%	13506	42.4	2290.0	3836	5.9	4.76	1912.0	
		75%	14456	47.3	2555.3	3962	5.7	5.10	2115.8	
		78%	14984	50.2	2710.3	4031	5.5	5.29	2232.9	
		81%	15544	53.3	2879.3	4101	5.4	5.49	2357.5	
		84%	16017	56.0	3025.6	4160	5.3	5.67	2469.9	
87%	16518	59.0	3184.3	4219	5.2	5.85	2584.4			
90%	17005	61.9	3340.3	4276	5.1	6.02	2695.4			
100%	17464	64.7	3489.8	4326	5.0	6.18	2799.4			

以上数据为好盈实验室于室温 25°C、海平面高度，变化油门输入调节测得。两款桨叶拉力数据相同。

The above data was measured by HOBBYWING Laboratory at room temperature 25°C, at sea level, with varying throttle input adjustments. The test data of two types of propellers are the same.

尺寸图 (D35管径)

Dimension Figure (Tube Outer Diameter D35 Version)

X8-G2-D35

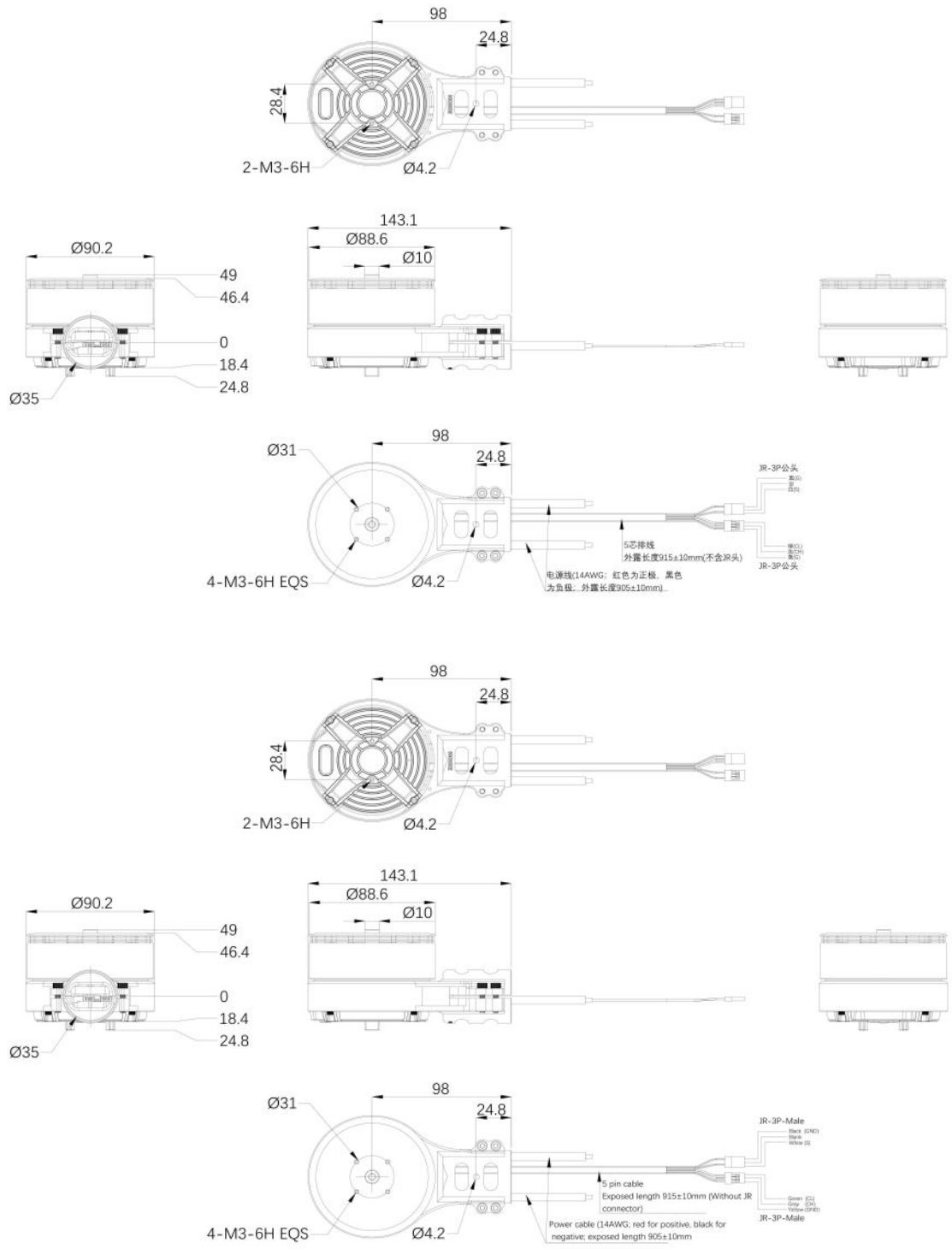

尺寸图 (D40管径)

Dimension Figure (Tube Outer Diameter D40 Version)

X8-G2-D40

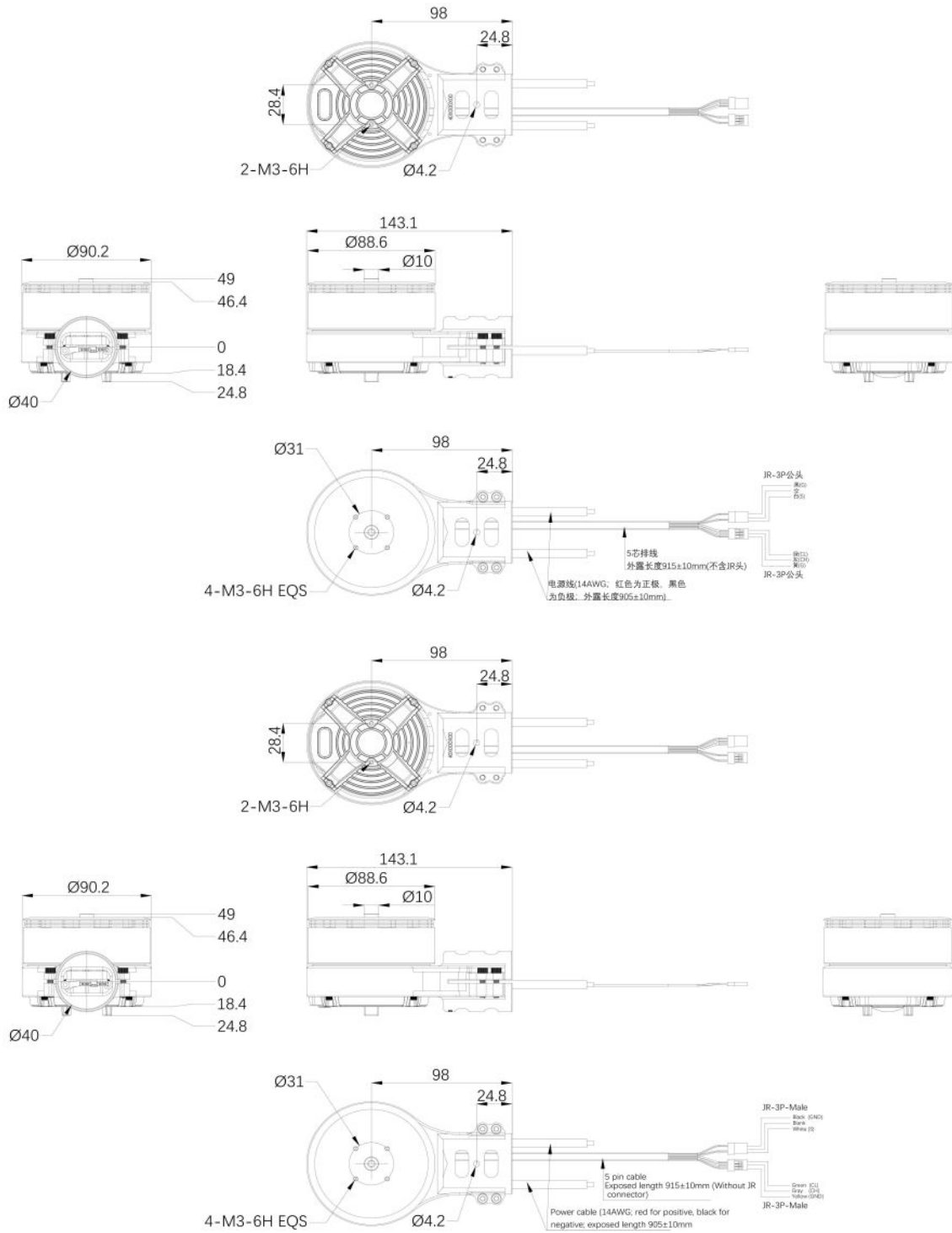

桨叶尺寸图 Dimension Figure of Propellers

30*11"S

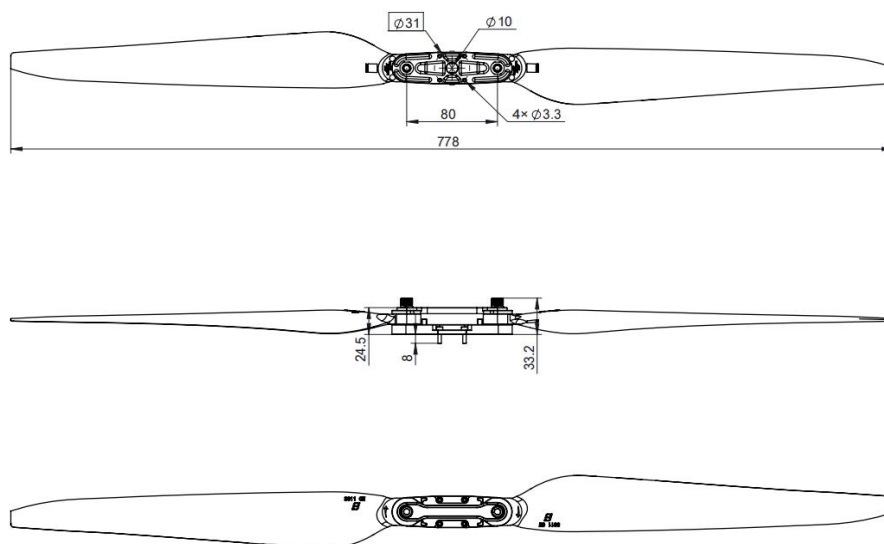

30*11"

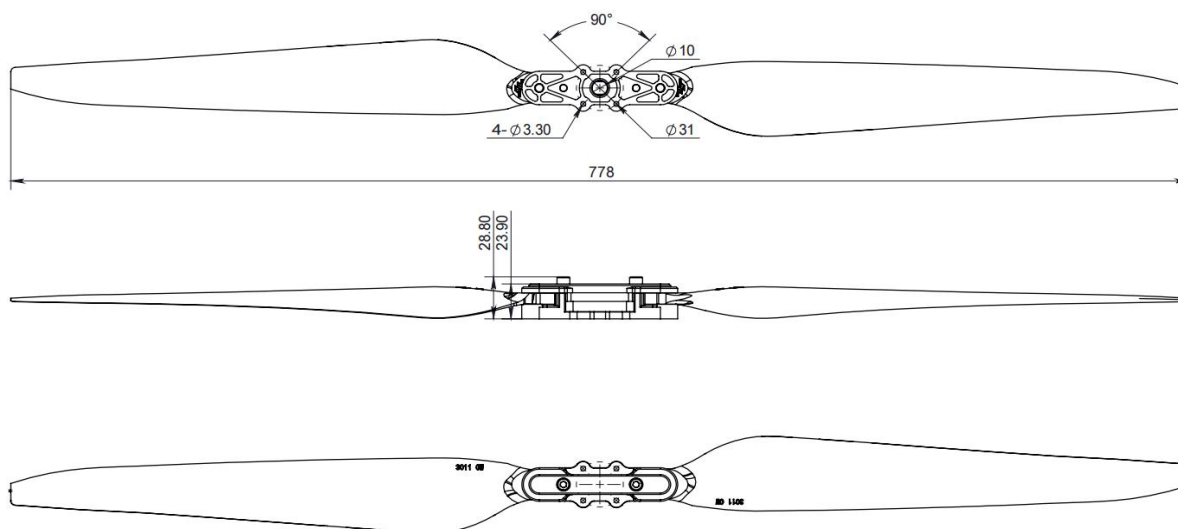

安装示意图 Installation Drawing

动力套装配示意 Assemble Steps

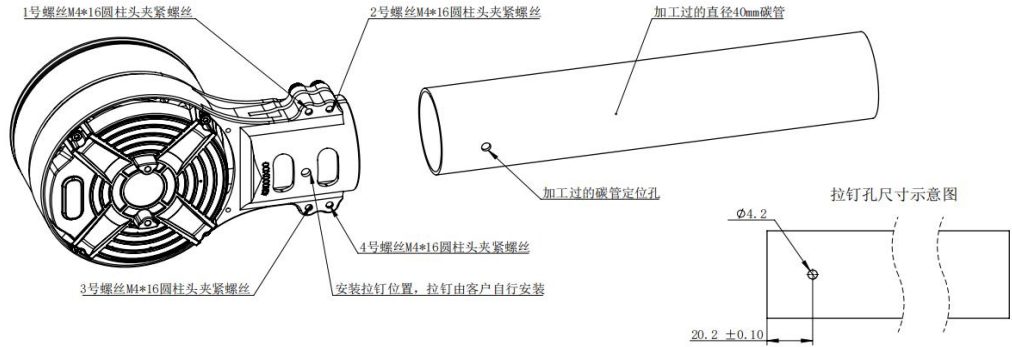

安装步骤:

- 1、先拧松管夹座上锁碳管1-4号的4颗螺钉, 将动力套线束穿过碳管, 碳管插入管夹座并推至底, 确保动力套装入后处于水平状态;
- 2、先旋1号夹紧螺丝, 再旋3号夹紧螺丝; 再旋2号夹紧螺丝, 再旋4号夹紧螺丝。以此类推, 锁到预紧状态切勿一次性锁紧;
- 3、1-4号夹紧螺丝锁紧扭力应在 $2.5 \pm 10\% \text{N} \cdot \text{m}$;
- 4、如有需要, 可在碳管上打孔, 并在管夹座上/下方预留孔位增加拉钉, 用于固定动力套。

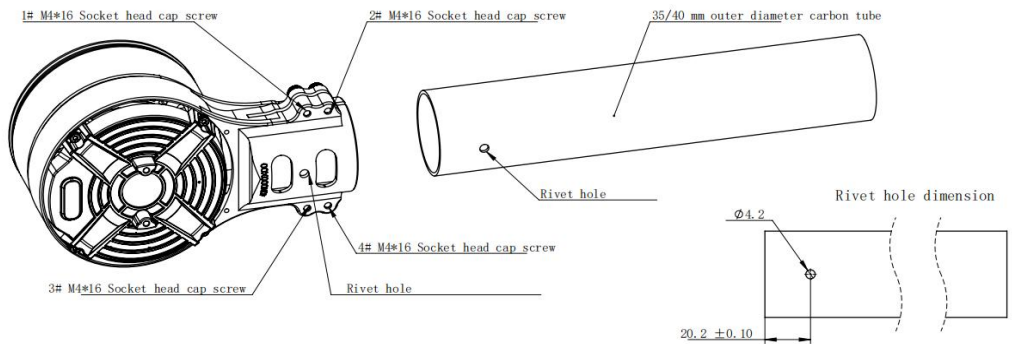

Installation steps:

1. First, loosen the four screws (#1-#4) on the tube clip holder for fixing the carbon tubes, then pass the propulsion system cable bundle through the carbon tubes, insert the carbon tubes into the tube clip holder, and push them to the bottom. Make sure that the propulsion system is horizontally positioned after installation.
2. Tighten #1 screw first, then #3 screw, followed by #2 screw, and finally #4 screw. Follow this order, and lock the screws to the pre-tightening state. Do not tighten all at once.
3. The tightening torque for #1-#4 should be $2.5 \pm 10\% \text{N} \cdot \text{m}$.
4. If necessary, holes can be drilled on the carbon tube, and holes reserved above or below the tube clip holder are for adding rivets to secure the propulsion system.