



MicroBrain Intelligent

UAV-R22-1 (UART) Single target UAV
obstacle avoidance radar sensor
user manual

2023. 12. 27

Microbrain Intelligent Technology Co., Ltd.

Disclaimer

Welcome to buy this product

Website: <http://microbrain.com.cn>

Before using this product, please read this statement carefully. Once used, it is regarded as recognition and acceptance of the content of this statement. Please strictly follow the manual installation and use the product. If there is an improper use, and the damage or damage caused, the comparison of technology does not bear the corresponding losses and compensation liability. This product is Microbrain Intelligent Technology Co.,Ltd All rights reserved. Without permission, it is not allowed to copy and reprint them in any form. The use of products and manuals will not be held accountable.

Historic version

Date	Version	Version description
2023. 12. 27	1.0	UAV-R22-1 Open source flight controller application

Catalog

1、Product Introduction of UAV-R22-1	2
2、Product Features	错误！未定义书签。
3、Product Parameters	错误！未定义书签。
4、Product Picture	错误！未定义书签。
5、Installation Method	错误！未定义书签。
6、Quickly use steps	6
7、Precautions of product use	11
8、Frequently asked questions (FAQ)	12

1. UAV-R22-1 Introduction

UAV-R22-1(UART)Obstacle avoidance radar is a lightweight mmWave radar sensor that is intelligently developed and produced by Microbrain Intelligent. It has high measurement accuracy, small body shape, high sensitivity, light weight, easy integration, and stable performance. This product uses a fan -shaped 77GHz electromagnetic wave and processed the echo signal to determine whether there are obstacles ahead, the relative distance, speed, orientation corner of the feedback obstacle to the radar, and guide the radar carrier such as drones to avoid obstacles, Ensure their safe work

UAV-R22-1(UART)Medium distance radar has the following characteristics:

- 2T4R MIMO array antenna design, $\pm 15^\circ$ azimuth FOV, High angular resolution and angular detection accuracy;
- Operating frequency is 77GHz~81GHz, sensitive to moving target, high range detection accuracy;
- Effective detection distance 27m;
- Support UART protocol output, Default baud rate115200;
- Single chip DSP+ARM dual-core architecture signal processing and control unit , radar data processing, target detection, target tracking and other algorithms are runned on the internal high-speed digital signal processor

2. Product Feature

- Type: Obstacle avoidance radar sensor
- Model: UAV-R22-1
- Dimension: 76*71.5*19.6mm
- Weight: approx. 87g (including cable)
- Protection rating: IP67

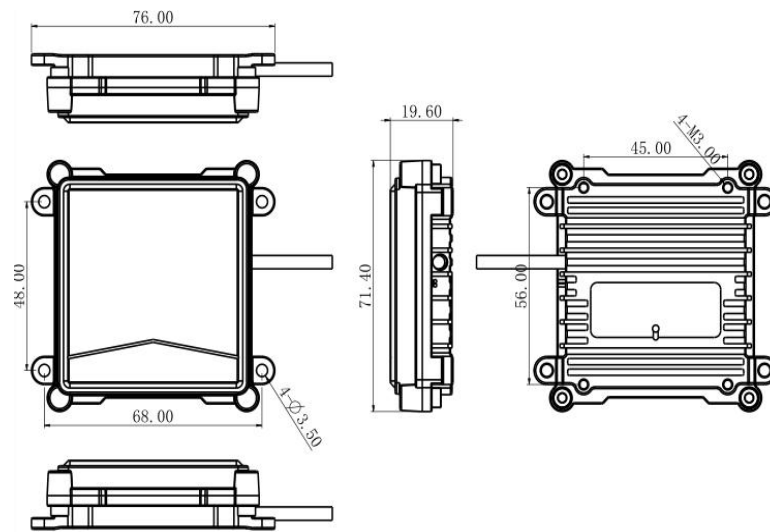

Picture 1 UAV-R22-1

3. Product Parameters

Item	Parameters	Value
Antenna performance	Azimuth	$\pm 15^\circ$
	Elevation	$-5^\circ \sim +3^\circ$
	EIRP (dBm)	30
Radar performance	Distance detection range (m)	1.5~27
	Distance detection accuracy (m)	0.02
	Distance detection resolution (m)	0.18

Radar property	Frequency (GHz)	79
	Refresh rate(Hz)	20
	Bandwidth(GHz)	1.4
System property	Working voltage (V)	5-24
	Working Temperature	-40℃~85℃
	Power consumption(W)	3W
	Protection rating	IP67
	Communication Interface	UART
	PCB size (mm)	55*52*1.6

4. Product Picture

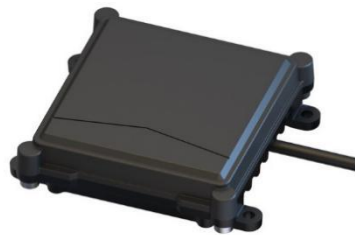

Picture 2 UAV-R22-1

5. Installation Method

UAV-R22-1 Radar Installation Step:

- Installation location: Radar Horizontal beam $\pm 15^\circ$ (Azimuth), vertical beam $-3^\circ \sim +5^\circ$ (Elevation), make sure there shall be no any obstacle within the beam range during installation

- Installation direction: radar transceiver antenna is located at the back side (arrow sign). During installation, the arrow is down, radar cable to left, radar front to the drone flying direction.

● Installation angle: antenna surface (radar front) to the drone front. Based on the maximum downward inclination angle of the drone's flying attitude, radar is installed by tilting upward. The optimal installation tilt angle is related to the drone maximum tilt angle during flight and the height above the ground. and the general installation tilt angle is 12° .

Suppose the drone maximum tilt angle during flight is θ , drone operating altitude is H, Maximum warning distance R_{\max} , The expression is as follows:

$$\frac{H}{\sin(\theta+3)} > R_{\max}$$

After calculation, it can be obtained that:

$$\theta < \arcsin\left(\frac{H}{R_{\max}}\right) - 3$$

Suppose $\theta_0 = \arcsin\left(\frac{H}{R_{\max}}\right) - 3$, θ_0 is the largest tilt angle which can be accepted when the radar is installed horizontally, If the drone tilt angle is larger than θ_0 , then it needs to be corrected, that is, the radar installed upward, installation angle θ_{comp} , Make it $\theta - \theta_{\text{comp}} < \theta_0$.

Installation angle:

$$\theta_{\text{comp}} > \theta - \theta_0$$

It should be pointed out that the better the stability of the drone platform, the smaller the fluctuation of the radar beam in the elevation direction, the smaller of the θ_{comp} , the more stable detection of radar front obstacle.

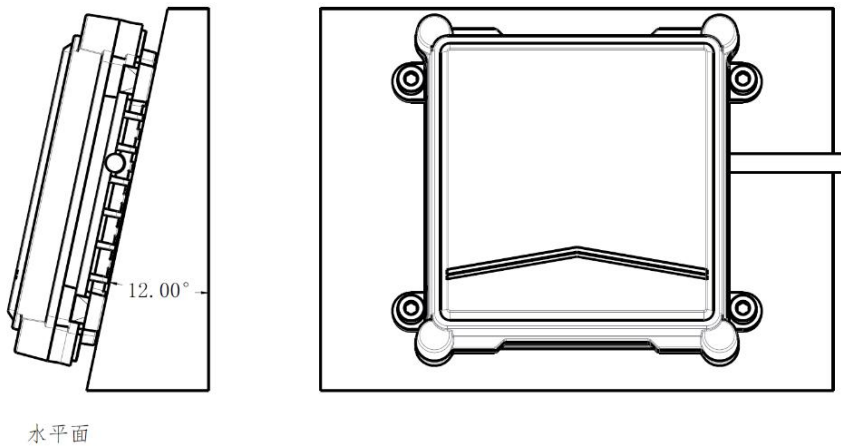

Picture 3 Radar installation

6. Quickly use steps

● Pin Definition

UAV-R22-1 The interface pin definition of the sensor, as shown in the table 1:

PIN	Definition	Range
1	POWER_IN (Red)	5~24V DC
2	GND (Black)	-
3	TX (Green)	0~3.3V
4	RX (White)	0~3.3V

Table 1: UAV-R22-1 Pin interface definition

● Testing using

Superior machine testing software provided by Microbrain Intelligent can obtain and analyze UAV-R22-1 sensor data, and intuitively display the observation results. Use this tool to help the use of UAV-R22-1 obstacle avoidance radar distance detection

Use the UART protocol test method as follows:

First obtain UAV-R22-1 upper computer test software from Microbrain Intelligent

customer service or website. Please install and configure the upper computer testing software according to the manual.

Table 3 Testing tools

No.	Device	Number
1	UAV-R22-1 radar sensor	1
2	PC	1
3	TTL-USB	1
4	5~24V power adapter	1
5	Upper computer test software	1

1) Through TTL-USB module, Connect PC with UAV-R22-1 radar sensor, picture as follow :

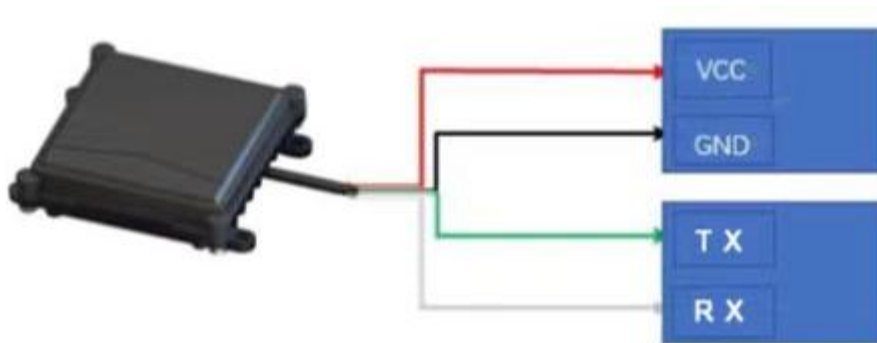

Picture 4 Serial port line connection

Connect with PC and radar sensor, open upper computer test software, Click to start ,the test result as shown in the figure follow

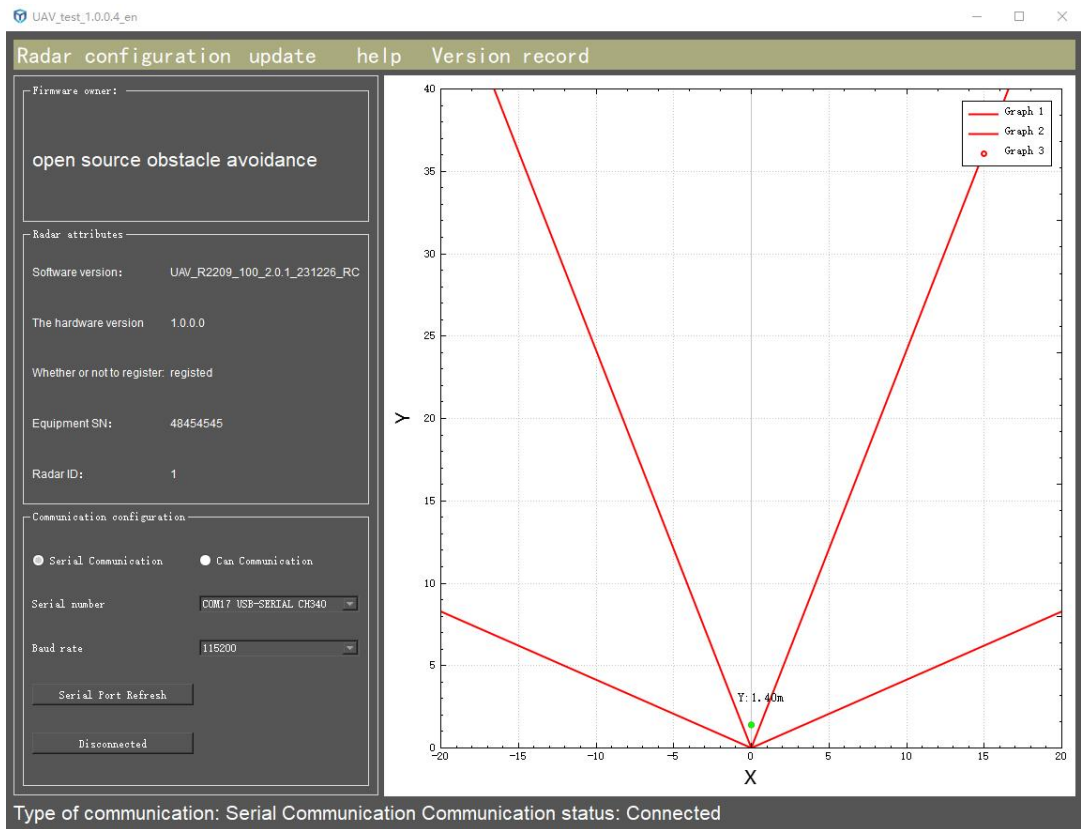

● Serial data analysis

UAV-R22-1radar sensor outputs the Y coordinate of the recent obstacle. as shown in the figure below, obstacle 1 is not within the range of radar beams, can not be detected by radar. Among the obstacle 2, 3 and 4, the distance between obstacle 2 is the closest to Y2, The final output value of radar is Y2

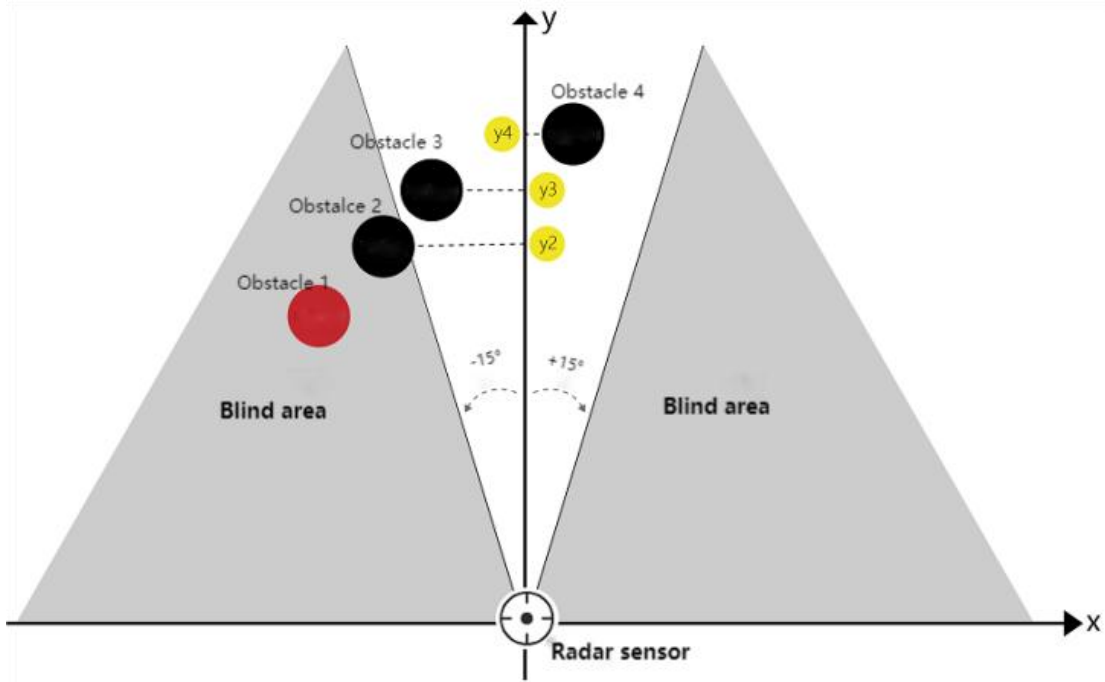

Picture 4

Serial port baud rate 115200, Support 3.3V electric level, Data refresh rate 20Hz, Data unit (cm), Send specified data packet format according to customer needs, Each frame of data packet is executed according to the customer's protocol. UAV-R22-1 data as follow.

UAV-R22-1 77GHz mmWave radar is UART output, 115200bps, 8N1.

Output Frequency 20Hz. Specific protocol format is as follows:

Header Byte D1 D2 D3 D4 D5 D6 D7 D8 D9 CRC

Byte	Parameter Description		Unit	Explanation	Remark
Byte 0	Header Byte 1	uint8_t		Fixed'T', that is 0x54	
Byte 1	Header Byte 2	uint8_t		Fixed'H', that is 0x48	
Byte 2~3	D1	uin16_t	cm	0 degree sector obstacle distance	
Byte4~5	D2	uin16_t	cm	45 degree sector obstacle distance	
Byte 6~7	D3	uin16_t	cm	90 degree sector	

				obstacle distance	
Byte 8~9	D4	uin16_t	cm	135 degree sector obstacle distance	
Byte10~11	D5	uin16_t	cm	180 degree sector obstacle distance	
Byte 12~13	D6	uin16_t	cm	225 degree sector obstacle distance	
Byte 14~15	D7	uin16_t	cm	270 degree sector obstacle distance	
Byte 16~17	D8	uin16_t	cm	315 degree sector obstacle distance	
Byte 18	D9	Uin8_t		Fixed, 'M' ascii is decimal 77 (0x4D)	
Byte 19	CRC	Uin8_t		CRC8 check	See description below

Obstacle Distance Unit: millimeter. The high 8 bits are in front, the low 8 bits are in the back.

for example, 0 degree sector obstacle distance 0x07D0.

Byte 2=0x07, byte 3=0xD0, then the actual distance is 2m.

Note: It must be sent regardless of whether there is radar data or not. When the data is invalid, DX is filled with 0xFFFF. UAV-R22-1 77GHz MMwave radar obstacle avoidance system outputs D1, D2, D3, D4...D8 sector obstacle distances, and other sectors are invalid data. Fill with 0xFFFF.

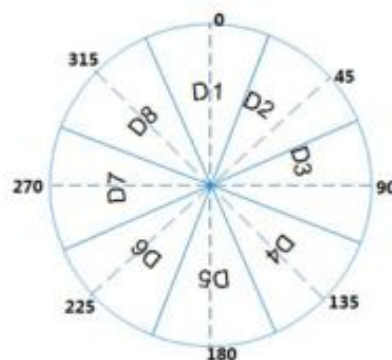

Radar output CRC8 check

Crc.cpp:

```
static const uint8_t crc8_table[] = {
0x00, 0x07, 0x0e, 0x09, 0x1c, 0x1b, 0x12, 0x15, 0x38, 0x3f, 0x36, 0x31,
0x24, 0x23, 0x2a, 0x2d, 0x70, 0x77, 0x7e, 0x79, 0x6c, 0x6b, 0x62, 0x65,
0x48, 0x4f, 0x46, 0x41, 0x54, 0x53, 0x5a, 0x5d, 0xe0, 0xe7, 0xee, 0xe9,
0xfc, 0xfb, 0xf2, 0xf5, 0xd8, 0xdf, 0xd6, 0xd1, 0xc4, 0xc3, 0xca, 0xcd,
0x90, 0x97, 0x9e, 0x99, 0x8c, 0x8b, 0x82, 0x85, 0xa8, 0xaf, 0xa6, 0xa1,
0xb4, 0xb3, 0xba, 0xbd, 0xc7, 0xc0, 0xc9, 0xce, 0xdb, 0xdc, 0xd5, 0xd2,
0xff, 0xf8, 0xf1, 0xf6, 0xe3, 0xe4, 0xed, 0xea, 0xb7, 0xb0, 0xb9, 0xbe,
0xab, 0xac, 0xa5, 0xa2, 0x8f, 0x88, 0x81, 0x86, 0x93, 0x94, 0x9d, 0x9a,
0x27, 0x20, 0x29, 0x2e, 0x3b, 0x3c, 0x35, 0x32, 0x1f, 0x18, 0x11, 0x16,
0x03, 0x04, 0x0d, 0x0a, 0x57, 0x50, 0x59, 0x5e, 0x4b, 0x4c, 0x45, 0x42,
0x6f, 0x68, 0x61, 0x66, 0x73, 0x74, 0x7d, 0x7a, 0x89, 0x8e, 0x87, 0x80,
0x95, 0x92, 0x9b, 0x9c, 0xb1, 0xb6, 0xbf, 0xb8, 0xad, 0xaa, 0xa3, 0xa4,
0xf9, 0xfe, 0xf7, 0xf0, 0xe5, 0xe2, 0xeb, 0xec, 0xc1, 0xc6, 0xcf, 0xc8,
0xdd, 0xda, 0xd3, 0xd4, 0x69, 0x6e, 0x67, 0x60, 0x75, 0x72, 0x7b, 0x7c,
0x51, 0x56, 0x5f, 0x58, 0x4d, 0x4a, 0x43, 0x44, 0x19, 0x1e, 0x17, 0x10,
0x05, 0x02, 0x0b, 0x0c, 0x21, 0x26, 0x2f, 0x28, 0x3d, 0x3a, 0x33, 0x34,
0x4e, 0x49, 0x40, 0x47, 0x52, 0x55, 0x5c, 0x5b, 0x76, 0x71, 0x78, 0x7f,
0x6a, 0x6d, 0x64, 0x63, 0x3e, 0x39, 0x30, 0x37, 0x22, 0x25, 0x2c, 0x2b,
0x06, 0x01, 0x08, 0x0f, 0x1a, 0x1d, 0x14, 0x13, 0xae, 0xa9, 0xa0, 0xa7,
0xb2, 0xb5, 0xbc, 0xbb, 0x96, 0x91, 0x98, 0x9f, 0x8a, 0x8d, 0x84, 0x83,
0xde, 0xd9, 0xd0, 0xd7, 0xc2, 0xc5, 0xcc, 0xcb, 0xe6, 0xe1, 0xe8, 0xef,
0xfa, 0xfd, 0xf4, 0xf3
};
uint8_t crc_crc8(const uint8_t *p, uint8_t len)
{
    uint16_t i; uint16_t crc = 0x0;
    while (len--)
    {
        i = (crc ^ *p++) & 0xFF; crc = (crc8_table[i] ^ (crc << 8)) & 0xFF;
    }
    return crc & 0xFF;
}
```

Debugging way: `crc8 = crc_crc8(buffer, 1);` //buffer is the data receiving buffer array

7. Precautions of product use

- Radar needs to be fully protected against static electricity during transportation, storage, operation and handling. If there is no target object within the radar detection coverage, The radar continues to

output irregular targets or when DC parameter values such as power supply voltage and source current are within the normal range, the output signal cannot be obtained, then the radar may be damaged

- Please keep the radar cover clean during installation. To clean the cover, wipe it with a soft damp cloth and then let it dry naturally
- When installing, please pay attention to the shape of the radar and ensure that the installed radar is not deformed. Do not squeeze, bump, or beat it.
- When installing, make sure the radar is the factory original. Do not disassemble or assemble by yourself.

8. FAQ

- 1) What is the radar detection range? Why is the minimum detection distance 1.5m?

Answer: The obstacle avoidance radar sensor detection distance is 1.5–27m, consider the length of the wing, The drone radar needs to be >1.5m away from obstacles, so the minimum detection distance is 1.5m

- 2) What is the recommended installation angle?

Answer: Based on the above installation angle suggestions and our company's test results, it is recommended that the general flight controller be installed with an upward tilt of 12°.

- 3) When the radar does not detect obstacles, is there any data output?

Answer: The radar outputs data in real time. When the radar does not detect an obstacle or the obstacle distance is greater than 27m, the output data is 0. When the radar detects an obstacle, the output is the actual distance of the obstacle.

If you encounter problems that cannot be solved during the installation process, please contact the customer service staff of Microbrain Intelligent Technology Co., Ltd.

Microbrain Intelligent Technology Co., Ltd

<https://www.microbrain.com.cn/>

ADD: 3th Floor, Building A, Chentai Science Park, Wanglong Road No. 56, Yuelu District, Changsha city, 410205, PRC

Tel: 400-0731-508

