

Air602 AT Command User Manual

V1.1

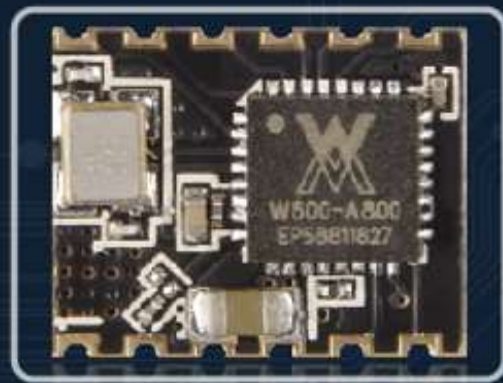

Air602 WiFi
Module

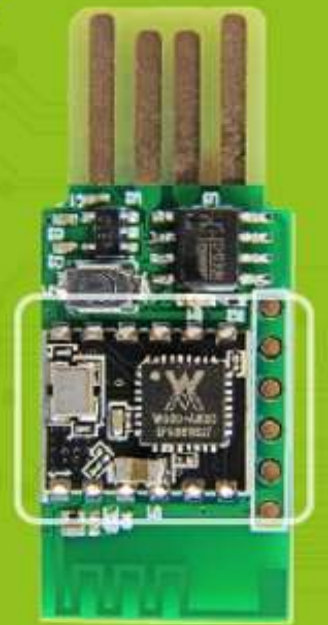

Air602 WiFi
Development Board

Created by Luat, translated by seed



Document version

Version	Data	Modify record	Author	Review	Approve
V1.0.0	2018-03-29	create	Mrbenlu	Craoy	Luat
V1.0.1	2018-08-04	Improve documentation	Mrbenlu	Craoy	Luat
V1.0.2	2018-08-05	Improve documentation	Mrbenlu	Craoy	Luat
V1.1	2018-08-08	Improve documentation, add examples, add MQTT	Winny		
V1.1 English	2018-10-24	Completed the English translation based on version 1.1	Jelly	Bill	Seed



Contents

1	Introduction	6
1.1	Overview.....	6
1.2	Control Command Protocol.....	6
1.2.1	Command Code.....	6
1.2.2	Error Code.....	9
2	AT Command Protocol	10
2.1	Syntax Description.....	10
2.2.1	Syntax Format.....	10
2.1.1.1	Processing Flow.....	11
2.1.1.2	Example Format.....	12
2.2	Instruction Definition.....	13
2.2.1	System Control Class Instruction.....	13
2.2.1.1	Null Operation Instruction: AT+	13
2.2.1.2	System Reset: AT+Z	13
2.2.1.3	settings Echo : AT+E	14
2.2.1.4	Serial Port Enters Transparent Transmission Mode : AT+ENTM.....	14
2.2.1.5	Enter Energy Saving Mode : AT+ENTS	16
2.2.1.6	Reset Factory Settings : AT+RSTF.....	17
2.2.1.7	Save In-memory Parameters to FLASH : AT+PMTF	18
2.2.1.8	Get the physical address of the wireless network card in STA mode : AT+QMAC.....	19
2.2.1.9	Get the physical address of the wireless network card in SoftAP mode : AT+APMAC..	19
2.2.1.10	Get Version : AT+QVER	20
2.2.2	Parameter Setting Class Instruction.....	21
2.2.2.1	Wireless Netoperating mode : AT+WPRT.....	21
2.2.2.2	Query/set the local IP address in STA mode : AT+NIP	22
2.2.2.3	Query/set the local IP address in SoftAP mode : AT+APNIP	23
2.2.2.4	Network Card DNS: AT+DNS.....	24
2.2.2.5	Operating Mode: AT+ATM.....	24



2.2.2.6	Socket connection in automatic operating mode : AT+ATRM	25
2.2.2.7	Wireless Network Name : AT+SSID	27
2.2.2.8	SoftAP Wireless Network Name : AT+APSSID	27
2.2.2.9	Wireless Network Security Mode : AT+ENCRY	28
2.2.2.10	SoftAP Wireless Network Security Mode : AT+APENCRY	29
2.2.2.11	Network Key : AT+KEY	30
2.2.2.12	SoftAP Network Key : AT+APKEY	31
2.2.2.13	Set/query the BSSID address of the specified AP : AT+BSSID	33
2.2.2.14	Set/query the specified wireless channel mode : AT+CHL	33
2.2.2.15	Set / Query SoftAP Wireless Channel Mode : AT+APCHL	34
2.2.2.16	Wireless Channel List : AT+CHLL	34
2.2.2.17	Enable automatic creation of adhoc network functions : AT+WATC	35
2.2.2.18	Turn automatic energy saving mode on/off : AT+WPSM	35
2.2.2.19	Enable/disable AP SSID broadcast : AT+BRDSSID	37
2.2.2.20	UART Port Data Format : AT+UART	37
2.2.2.21	Built-in enable WEB management server : AT+WEBS	39
2.2.2.22	Device Name : AT+DNAME	39
2.2.2.23	System Login Password : AT+PASS	39
2.2.2.24	Receiving User Data : AT+CUSTDATA	40
2.2.2.25	Query the configured networking parameters : AT+CNTPARAM	40
2.2.3	Network Control Class Instruction	41
2.2.3.1	Network Card Interface Mode:AT+PORTM	41
2.2.3.2	Get the IP address of the external domain name : AT+SKGHBN	42
2.2.3.3	Set / Query WPS Features : AT+WWPS	42
2.2.3.4	Join The Specified AP : AT+WJOIN	43
2.2.3.5	Disconnect the Current Network : AT+WLEAV	45
2.2.3.6	Scan Wireless Network: AT+WSCAN	46
2.2.3.7	Query the local network connection status : AT+LKSTT	47
2.2.3.8	Set / Query SoftAP Status : AT+APLKSTT	48
2.2.3.9	Query the connected station : AT+SLIST	50
2.2.3.10	Build a socket connection : AT+SKCT	50



2.2.3.11	Send data through the specified socket : AT+SKSND	52
2.2.3.12	Read the data in the receive buffer of the specified socket : AT+SKRCV.....	53
2.2.3.13	Get the specified socket state : AT+SKSTT	54
2.2.3.14	Close the specified socket : AT+SKCLS	55
2.2.3.15	Set the socket sent by the system by default. : AT+SKSDF.....	55
2.2.3.16	Get the source IP address of the current socket received data : AT+SKSRCIP	56
2.2.3.17	Socket actively reports receiving data : AT+SKRPTM	56
2.2.3.18	One-click configuration : AT+ONESHOT	57
2.2.3.19	HTTP client post get function : AT+HTTTPC	58
2.2.4	MQTT Instruction.....	59
2.2.4.1	Set up the MQTT server : AT+MSERVER.....	59
2.2.4.2	Set login account and password : AT+MLOGIN.....	59
2.2.4.3	Set Client ID: AT+MID.....	59
2.2.4.4	Connect to the MQTT server : AT+MCONNECT	60
2.2.4.5	Subscribe to a topic : AT+MSUB	60
2.2.4.6	Post a message : AT+MPUB	61
2.2.4.7	Received a message : AT+MTOPIC,AT+MQD	61
2.2.4.8	Close the MQTT server : AT+MCLOSE.....	61
2.2.4.9	MQTT Result Code.....	62
2.2.4.10	MQTT Usage Example.....	63
3	Common operation.....	65
3.1	Create a SoftAP Process.....	65
3.2	Scan AP Process.....	66
3.3	STA joins the AP Process.....	66
3.4	Create an APSTA Process.....	67
3.5	How the STA disconnects the AP.....	68
3.6	SoftAP Disconnected.....	68
3.7	How STAs view current status.....	68
3.8	View current SoftAP status.....	68
3.9	How to use the socket function.....	68
3.10	Transparent transmission application in automatic operating mode.....	73



1 Introduction

1.1 Overview

This manual describes the AT+ command communication protocol of the Luat embedded Wi-Fi module. The AT+ command protocol uses a set of command based on ascii to communicate with the Wi-Fi chip through the UART interface.

1.2 Control Command Protocol

1.2.1 Command Code

This section is a user command for implementing parameter configuration and networking transmission of the product. The command list is as follows:

Number	Instruction Name	Function
1	(null)	Null Operation Instruction
2	ATM	Set/query operating mode
3	ATRM	Set/query socket connection information automatically created in automatic operating mode
4	BSSID	Set/query the BSSID address of the specified AP
5	BRDSSID	Enable and disable the SSID broadcast of the AP
6	CHL	Set/query the specified wireless channel mode
7	CHLL	Set/Query Wireless Channel List
8	CNTPARAM	Query the configured networking parameters
9	CUSTDATA	Receive user data sent via one-click configuration tool
10	DNAME	Set/query device name
11	DNS	Set domain name of network card



12	E	Switch serial port character echo
13	ENCRY	Set/Query Wireless Network Security Mode
14	ENTM	Enter serial port transparent transmission mode
15	ENTS	Set the system to enter energy saving mode
16	HTTPC	HTTP post get data function
17	KEY	Set/Query Wireless Network Key
18	LKSTI	Query network connection status
19	LKSTT2	Query network connection status 2, valid only in APSTA mode
20	NIP	Set/query the local IP address
21	ONESHOT	Turn one-click configuration on or off
22	PASS	Set / query system password
23	PMTF	Update all parameters in memory to Flash
24	PORTM	Set the interface mode of the wireless network card
25	QMAC _____	Query physical address
26	QMAC2	Query physical address 2, valid only in APSTA mode
27	QVER _____	Query version information
28	RSTF	Reset Factory settings
29	SKCLS	Close socket connection
30	SKCT	Create a socket connection
31	SKGHBN	Get the IP of the server
32	SKRCV	Receive data via a Socket connection



33	SKRPTM	Open or close the socket to actively report the receiving data function
34	SKSDF	Set the default send socket connection
35	SKSND	Send data over a socket connection
36	SKSRCIP	Query socket data source IP address
37	SKSTT	Query socket connection status
38	SLIST	Query the STAs that have been connected, valid only in AP and APSTA modes.
39	SSID	Set/Query Wireless Network Name
40	SSID2	Set/query the wireless network name, valid only in APSTA mode
41	UART	Set / query serial data format
42	WATC	Set/Query to automatically create an Adhoc network
43	WEBS	Set/Query Web Server
44	WJOIN	Join/create a wireless network
45	WLEAV	Disconnect wireless network
46	WPRT	Set/Query Wireless Network Type
47	WPSM	Turn energy saving mode on/off
48	WSCAN	Scan Network
49	WWPS	Set / Query WPS Features
50	Z	Reset

1.2.2 Erro Code

The error codes supported by this system are defined as follows:

ASCII	Description
-	Success
-1	Invalid command format
-2	Command not supported
-3	Invalid operator
-4	Invalid parameter
-5	Operation not allowed
-6	Not enough memory
-7	FLASH error
-8	System busy
-10	access the network failed
-11	No socket available
-12	Invalid socket
-13	Socket connection failed
-62	Socket failed to send
-63	Socket reception failed
-64	Undefined error



2 AT Command Protocol

2.1 Syntax Description

This module uses the AT+ command protocol as the user control protocol. The AT+ instruction protocol uses a set of command line format instruction sets based on ascii. The syntax format and processing flow are described below.

2.2.1 Syntax format

- Format Description

<>: Indicates the part that must be included

[]: Indicates the optional part

- Command Message

AT+<CMD>[op][para1],[para2],[para3],[para4]...<CR> AT+

: Command message prefix

CMD: Command String

[op]: Instruction operator, when the command needs to take a parameter, you can specify the operation type of the parameter, including:

=, Parameter/Return value preamble

=!, In the setting parameter class command, it means that the modification is synchronized to flash, and the restart does not disappear. ; If there is no ! after = , it means that it is only saved in memory, and the parameters disappear after restarting.

=?, In the Set Parameter Class command, query the current settings.

<CR>: Carriage Return, ascii character 0x0d

- Response message

+<RSP>[op][para1],[para2],[para3],[para4]...<CR><LF><CR><LF>

+: Response message prefix

RSP: Response string

OK Success

ERR Failure

<CR>: Carriage Return, ascii character 0x0d

<LF>: Line feed, ascii character 0x0a

- Data Type

String: String, Surrounded by double quotes, the content does not contain quotes,

e.g.: "this is a string"

Dec: Decimal number ,

e.g.: 10

Hex: Hexadecimal number ,

e.g.: a

Ip: ip address string ,

e.g.: 192.168.0.1

MAC: Consists of 12 hexadecimal digits ,

e.g.: 001EE3A80102

2.1.1.1 Processing flow

The AT+ instruction protocol takes the form of command + response. Most instructions require the receiver to return a response message after processing. If a new command is received again during the previous command processing, it will be silently discarded without returning. Any message, as shown below:

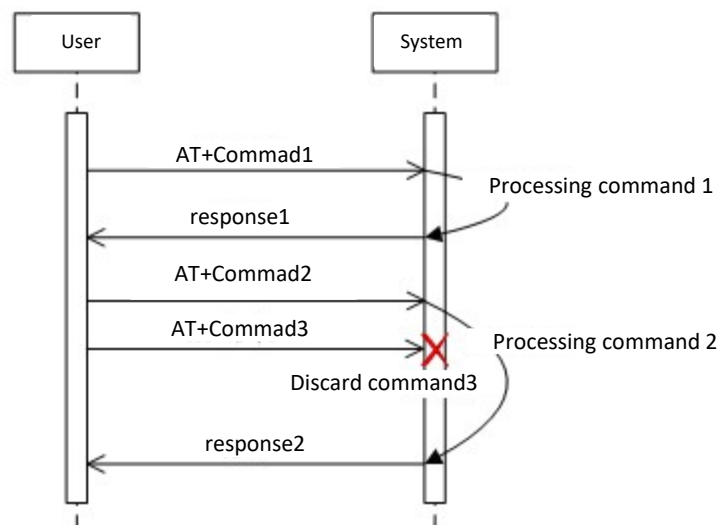

For some special commands, such as AT+SKSND, AT+SKRCV, it is necessary to transmit binary data after the instruction or response details. At this time, the receiver of the command transmission temporarily enters the transparent transmission state and starts receiving the binary data stream until receiving the specified length of data in the <size> field of the message or command, or until the waiting timeout, automatically exits the transparent transmission state, the flow is as follows:

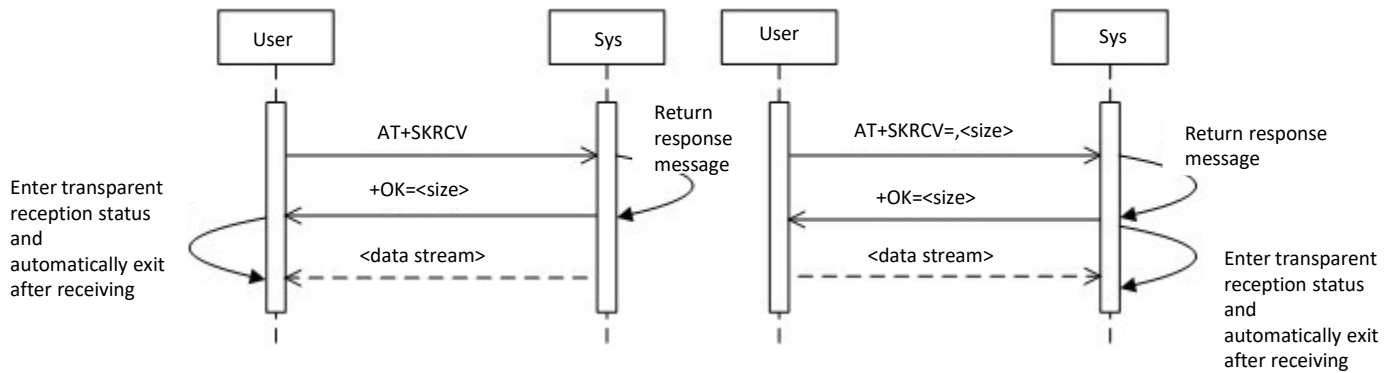

2.1.1.2 Example Format

examl1: Return success message

```
AT+
+OK
```

Example 2: Return error message

```
AT+WJOIN
+ERR=-10
```

Example 3: Set input parameters

```
AT+UART=9600,1,1,0
+OK
```

Example 4: Synchronizing parameters to the Flash operator <!>



```
AT+ATPT=!500
+OK
```

Example 5: Using the Query Operator <?>

```
AT+ATPT=?
+OK=500
```

2.2 Instruction Definition

2.2.1 System Control Class Instruction

2.2.1.1 Null Operation Instruction: **AT+**

- Function: empty operation, can be used to detect whether the program is responding normally
- Format (**ASCII**) :

```
AT+<CR>
+OK<CR><LF><CR><LF>
```

- Parameter: Null
- e.g.: (→ indicates input, ← indicates return or active report, the same below)

→	AT+
←	+OK

2.2.1.2 System Reset: **AT+Z**

- Function: System Reset .
- Format (**ASCII**) :



```
AT+Z<CR>
+OK<CR><LF><CR><LF>
```

- Parameter: Null

- e.g.:

→	AT+Z
←	+OK ready

2.2.1.3 Set Echo: **AT+E**

- Function: Switch serial port command echo
- Format (**ASCII**) :

```
AT+E<CR>
+OK<CR><LF><CR><LF>
```

- Parameter: Null

- e.g.:

→	AT+E
←	+OK

2.2.1.4 Serial port enters transparent transmission mode : **AT+ENTM**

- Function: Serial port enters transparent transmission mode ;the system exits this mode when it receives an escape character that matches the trigger condition in transparent transmission mode.

Attention: Before entering the transparent transmission mode, the following conditions must be met:

1. Connected to the Internet
2. Create a socket
3. Set the transparent connection to the currently created socket



- Format (**ASCII**) :

```
AT+ENTM<CR>
+OK<CR><LF><CR><LF>
```

- Parameter: Null
- e.g.: Entering the transparent mode requires the following steps:

1. Connect to the internet

→	AT+E
←	+OK
→	AT+KEY=1,0,""
←	+OK
→	AT+WJOIN
←	+OK=3c46d82bd81e,0,11,0,"TP-LINK_Luat_AP",51

2. Creat a socket

→	AT+SKCT=0,0, 36.7.87.76,1000,2000
←	+OK=1

3. Set the transparent connection to the currently created socket

→	AT+SKSDF=1
←	+OK

4. Entering the transparent mode

→	AT+ENTM
←	+OK

2.2.1.5 Energy saving mode : **AT+ENTS**

- Function: Set the system to enter the energy saving mode (Wi – Fi OFF / sleep / standby state)
- Format (**ASCII**) :

```
AT+ENTS=[ps_type],[wake_type],[delay_time],[wake_time]<CR>
+OK<CR><LF><CR><LF>
```

- Parameter:

ps_type: Energy saving mode

Value	Description
0	Wi-Fi OFF
1	Standby
2	Sleep

wake_type: Wake mode

Value	Wi-Fi OFF Mode	Sleep /Standby Mode
0	Disable	Wakeup pin wakes up
1	Enable	Timer wakes up

delay_time: Delay time, unit ms, Valid value 100~1000

wake_time: Wake time, unit ms, Valid value 1000 ~ 65535



Attention:

- ① In the Wi-Fi OFF energy saving mode, the setting is valid only when the network is disconnected, and the wake_time parameter is meaningless.
- ② Standby and sleep power-saving modes will cause the network connection to be disconnected and the wake-up will be reset.
- ③ Set WAKEUP pin wake mode, the wake_time parameter is meaningless.

• e.g.:

1. Wi-Fi OFF energy saving mode

Enter Wi-Fi OFF energy saving mode :

```
AT+ENTS=0,1,1000,10000
```

Exit Wi-Fi OFF energy saving mode :

```
AT+ENTS=0,0,100,1000
```

2. standby mode

Set timer wake-up mode, unit ms, (delay 1s, wake up after 10s)

```
AT+ENTS=1,1,1000,10000
```

Set WAKEUP pin wake up mode (wake_time parameter is meaningless)

```
AT+ENTS=1,0,1000,10000
```

3. sleep mode

The same as standby mode

2.2.1.6 Reset Reset Factory Settings : **AT+RSTF**

- Function: Restore the factory settings in FLASH; the restored settings will not take effect until the system is restarted.

- Format (**ASCII**) :

```
AT+RSTF<CR>
+OK<CR><LF><CR><LF>
```

- Parameter: Null

- E.g.:

→	AT+RSTF
←	+OK

2.2.1.7 Save in-memory parameters to FLASH : **AT+PMTF**

- Function: Update all parameters saved in memory to FLASH
- Format (**ASCII**) :

```
AT+PMTF<CR>
+OK<CR><LF><CR><LF>
```

- Parameter: Null
- e.g.:

→	AT+WPRT=0
←	+OK
→	AT+SSID=TP-LINK_HyFi_1E
←	+OK
→	AT+KEY=1,0,""
←	+OK
→	AT+PMTF
←	+OK

The AT+PMTF command is equivalent to saving the parameters of the above three commands to the NV, so that these parameters do not need to be reset after the module is restarted or turned off. The effect is equivalent to saving the parameters of each command separately (as shown below):

→	AT+WPRT=!0
---	------------



←	+OK
→	AT+SSID=!TP-LINK_HyFi_1E
←	+OK
→	AT+KEY=!1,0,""
←	+OK

2.2.1.8 Get the physical address of the wireless network card in STA mode : **AT+QMAC**

- Function: Get the physical address of the wireless network card.
- Format (**ASCII**) :

```
AT+QMAC<CR>
+OK=<mac address><CR><LF><CR><LF>
```

- Parameter:

mac address: Physical address, the return format is as follows

Format	Description
ASCII Format command	a hexadecimal number of length 12, like: 001EE3A34455

- e.g.:

→	AT+QMAC
←	+OK=286dcd004e7d

2.2.1.9 Get the physical address of the wireless network card in SoftAP mode. : **AT+APMAC**

- Function: Obtain the SoftAP physical address, which is valid only in SoftAP and APSTA modes.



- Format (**ASCII**) :

```
AT+APMAC <CR>
+OK=<mac address><CR><LF><CR><LF>
```

- Parameter:

mac address: Physical address, the return format is as follows

Format	Description
ASCII Format command	a hexadecimal number of length 12, like : 001EE3A34455

e.g.:

→	AT+APMAC
←	+OK=2a6dcd004e7d

2.2.1.10 Get version information : **AT+QVER**

- Function: Get system version information, including hardware version and firmware version.
- Format (**ASCII**) :

```
AT+QVER<CR>
+OK=<firm><CR><LF><CR><LF>
```

- Parameter:

firm: Firmware version information

ASCII	String format , like " AirM2M_Luat_WiFi_V008_WM "
-------	---

e.g.:



→	AT+QVER
←	+OK=AirM2M_Luat_WiFi_V008_WM

2.2.2 Parameter Setting Class Instruction

2.2.2.1 Wireless Network Type: **AT+WPRT**

- Function: Set/Query Wireless Network Type
- Format (**ASCII**) :

```
AT+WPRT=[!?][type]<CR>
+OK[=type]<CR><LF><CR><LF>
```

Parameter:

type: Network Type

Value	Description
0	infra Network (STA mode)
1	adhoc Network
2	infra Network (AP mode)
3	infra Network (APSTA mode)

e.g.:

Set to SoftAp mode:

→	AT+WPRT=!2
←	+OK

2.2.2.2 Query/set the local IP address in STA mode : **AT+NIP**

- Function:

When the wireless network card is used as a STA, this command is used to set/query the local IP address. It should be noted that when the address type is set to DHCP Server, you cannot use this command to query the IP address information that the wireless network card actually allocates dynamically. Queries can use the AT+LKSTT command.

- Format (**ASCII**) :

```
AT+NIP=[!?][type],[ip],[netmask],[gateway],[dns]<CR>
+OK[=type,ip,netmask,gateway,dns]<CR><LF><CR><LF>
```

- Parameter:

Type: Address type

Value	Description
0	Dynamically assign/enable DHCP Server using DHCP
1	Use static IP address / disable DHCP Server

ip: ip address, data format "192.168.1.22", Without quotes

netmask: Subnet mask, data format is the same as ip address

gateway: Gateway address, data format is the same as ip address

dns: DNS address, data format is the same as ip address

- e.g.:

→	AT+WPRT=!0
←	+OK
→	AT+NIP=!0
←	+OK
→	AT+SSID=!TP-LINK_HyFi_1E
←	+OK



→	AT+KEY=!1,0,""
←	+OK
→	AT+WJOIN
←	+OK=3c46d82bd81e,0,11,0,"TP-LINK_HyFi_1E",59
→	AT+LKSTT
←	+OK=1,"192.168.1.124","255.255.255.0","192.168.1.1","192.168.1.1","0.0.0.0"
→	AT+NIP=?
←	+OK=0,192.168.1.1,255.255.255.0,192.168.1.1,192.168.1.1

Note: The above test shows that in the case of DHCP enabled, the second parameter queried by AT+NIP=? is not the IP address actually obtained by the module, and the second parameter queried by AT+LKSTT is.

2.2.2.3 Query/set the local IP address in SoftAP mode : **AT+APNIP**

- Function :

When the wireless network card is used as the SoftAP, this command is used to set/query the IP address of the local end and enable /disable the DHCP server. When the DHCP server is enabled, the IP address of the wireless network card can still be queried through this command.

- Format (ASCII) :

```
AT+APNIP=[!?][type],[ip],[netmask],[gateway],[dns]<CR>
+OK[=type,ip,netmask,gateway,dns]<CR><LF><CR><LF>
```

- Parameter :

type: addresstype

Value	Dscription
0	Dynamically assign/enable DHCP Server using DHCP
1	Use static IP address / disable DHCP Server



- ip**: ip address, data format "192.168.1.22", Without quotes
- netmask**: Subnet mask, data format is the same as ip address
- gateway**: Gateway address, data format is the same as ip address
- dns**: DNS address, data format is the same as ip address

- e.g.:

→	AT+APNIP=1,192.168.1.1,255.255.255.0,192.168.1.1,192.168.1.1
←	+OK

Please refer to this document for specific applications. [Create a SoftAP process](#)

2.2.2.4 Network Card DNS : **AT+DNS**

- Function:
Set/query the NIC module domain name. This setting is valid only when the NIC is used as SoftAP.
- Format (**ASCII**) :

```
AT+DNS=[!?][dnsname]<CR>
+OK[=dnsname]<CR><LF><CR><LF>
```

- Parameter:
dns name: NIC module domain name, 1~31 characters, surrounded by double quotes
- e.g.:

→	AT+DNS="DNS-FOR-TEST"
←	+OK

2.2.2.5 Operating Mode: **AT+ATM**

- Function:

Set / query the operating mode.

- Format (**ASCII**) :

```
AT+ATM=[!?][mode]<CR>
+OK[=mode]<CR><LF><CR><LF>
```

- Parameter:

mode: operating mode

Value	Description
0	Automatic working mode
1	Command mode

- e.g.: Query current working mode:

→	AT+ATM=?
←	+OK=1

Modify mode to automatic working mode :

→	AT+ATM=!0
←	+OK

2.2.2.6 Socket connection in automatic working mode : **AT+ATRM**

- Function:

Set/query the socket connection information automatically created in the automatic working mode.

- Format (**ASCII**) :

```
AT+ATRM=[!?][protocol],[cs],[host/timeout],[port]<CR>
+OK[=protocol,cs, host/timeout,port]<CR><LF><CR><LF>
```

- Parameter:

protocol: Protocol type

Value	Description
0	TCP
1	UDP

cs: C/S Mode

Value	Description
0	Client
1	Server

host_timeout: according to protocol and cs, its meaning is as follows

cs	protocol	Description
0	X	Destination server name, you can enter the domain name or ip address, e.g. "192.168.1.100" or " <u>www.sina.com.cn</u> "
1	0	The TCP connection timeout period, that is, the client connected to the server is automatically kicked off after sending no data for more than this time. The valid value range is 1~10000000, the unit is seconds, 0 means never, the default is 120 seconds.
1	1	Meaningless

port: The port number

- e.g.:

→	AT+ATRM=!0,0,180.97.81.180,51950
←	+OK

Please refer to: [Transparent transmission application in automatic working mode](#)



2.2.2.7 Wireless network name : **AT+SSID**

- Function:

Set/Query the name of the wireless network to be joined in STA mode , i.e.ssid.

- Format (**ASCII**) :

```
AT+SSID=[!?][ssid]<CR>
+OK[=ssid]<CR><LF><CR><LF>
```

- Parameter:

ssid: Wireless network name, 1~32 characters, with or without double quotes

- e.g.:

→	AT+SSID=! Air_Test_WiFi
←	+OK

Please refer to this part for details. : [STA joins the AP process](#)

2.2.2.8 SoftAP wireless network name : **AT+APSSID**

- Function:

The SoftAP wireless network name, SSID, is valid in SoftAP and APSTA modes.

- Format (**ASCII**) :

```
AT+APSSID=[!?][ssid]<CR>
+OK[=ssid]<CR><LF><CR><LF>
```

- Parameter:

ssid: Wireless network name, 1~32 characters, with or without double quotes

- e.g.:



→	AT+APSSID="AAAA-Test-Wifi"
←	+OK

Please refer to this part for specific applications. [Create a SoftAP process](#)

2.2.2.9 Wireless network security mode : **AT+ENCRY**

- Function :

Set/query wireless network security mode. It is important to note that in addition to the OPEN mode, other security modes need to be set with the correct network key in conjunction with the AT+KEY command. In addition, in AP or AD-HOC mode, the module only supports setting OPEN, WEP64, and WEP128.

- Format (**ASCII**) :

```
AT+ENCRY=[!?][encry mode]<CR>
+OK[=encry mode]<CR><LF><CR><LF>
```

- Parameter :

encry mode : security mode

Value	Dscription
0	OPEN
1	WEP64
2	WEP128
3	WPA-PSK(TKIP)
4	WPA-PSK(CCMP/AES)
5	WPA2-PSK(TKIP)
6	WPA2-PSK(CCMP/AES)

- e.g.: Query network security mode :

→	AT+ENCRY=?
←	+OK=0

Set the network security mode to WEP64:

→	AT+ENCRY=!1
←	+OK

2.2.2.10 SoftAP wireless network security mode : **AT+APENCRY**

- Function:

Set/Query SoftAP Wireless Network Security Mode. In addition to the OPEN mode, other security modes require the correct network key to be set with the AT+APKEY command.

- Format (ASCII) :

```
AT+ENCRY=[!?][encry mode]<CR>
+OK[=encry mode]<CR><LF><CR><LF>
```

- Parameter:

encry mode: security mode

Value	Dscription
0	OPEN
1	WEP64
2	WEP128
3	WPA-PSK(TKIP)



4	WPA-PSK(CCMP/AES)
5	WPA2-PSK(TKIP)
6	WPA2-PSK(CCMP/AES)

- e.g.:

Set the network security mode to WEP64:

→	AT+APENCRY=!1
←	+OK

2.2.2.11 Network key : AT+KEY

- Function:

Set/query the network key. It should be noted that before using this command to set the network key, you sometimes need to set the network security mode using the AT+ENCRY command.

- Format (**ASCII**) :

```
AT+KEY=[!?][format],[index],[key]<CR>
+OK[=format,index,key]<CR><LF><CR><LF>
```

- Parameter:

Format: Key format

Value	Description
0	HEX
1	ASCII

Index: Key index number, 1 to 4 is used for WEP encryption key. Other encryption methods are fixed at 0.

key: Key string, with or without quotes, according to different security modes, the length and format

requirements of the key usage are defined as follows:



Safe Mode	Key Format	
	HEX	ASCII
WEP64	10 hexadecimal characters ^(note1)	5 ASCII characters ^(note2)
WEP128	26 hexadecimal characters	13 ASCII characters
WPA-PSK(TKIP)	64 hexadecimal characters	8~63 ASCII characters
WPA-PSK(CCMP/AES)	64 hexadecimal characters	8~63 ASCII characters
WPA2-PSK(TKIP)	64 hexadecimal characters	8~63 ASCII characters
WPA2-PSK(CCMP/AES)	64 hexadecimal characters	8~63 ASCII characters

Note1: The hexadecimal characters are 0~9, a~f (not case sensitive), e.g. "11223344dd".

Note2: ASCII characters refer to the numbers in the standard ASCII character set specified by the International Organization for Standardization (ISO) 0~9 and the letters a~z (case sensitive), e.g. "14u6E".

- e.g.:

→	AT+KEY=!1,0,"A123456"
←	+OK

2.2.2.12 SoftAP network key : **AT+APKEY**

- Function:

Set/Query the SoftAP wireless network key. It should be noted that you must first set the wireless network security mode using the AT+APENCRY command before setting the network key using this command.

- Format (**ASCII**) :

```
AT+APKEY=[!?][format],[index],[key]<CR>
+OK[=format,index,key]<CR><LF><CR><LF>
```



- Parameter:

format: Key Format

Value	Dscription
0	HEX
1	ASCII

Index: Key index number, 1 to 4 is used for WEP encryption key. Other encryption methods are fixed at 0.
key: Key string, with or without quotes, according to different security modes, the length and format requirements of the key usage are defined as follows:

Safe Mode	Key Format	
	HEX	ASCII
WEP64	10 hexadecimal characters ^(note1)	5 ASCII characters ^(note2)
WEP128	26 hexadecimal characters	13 ASCII characters
WPA-PSK(TKIP)	64 hexadecimal characters	8~63 ASCII characters
WPA-PSK(CCMP/AES)	64 hexadecimal characters	8~63 ASCII characters
WPA2-PSK(TKIP)	64 hexadecimal characters	8~63 ASCII characters
WPA2-PSK(CCMP/AES)	64 hexadecimal characters	8~63 ASCII characters

Note1: The hexadecimal characters are 0~9, a~f (not case sensitive), e.g. "11223344dd".

Note2: ASCII characters refer to the numbers in the standard ASCII character set specified by the International Organization for Standardization (ISO) 0~9 and the letters a~z (case sensitive), e.g. "14u6E".

- e.g.:

→	AT+APKEY=!1,1,123456
←	+OK



2.2.2.13 Set/query the BSSID address of the specified AP : **AT+BSSID**

- Function:

Set/query the BSSID address of the specified AP. This setting is valid only on the infra network when the module functions as a STA.

- Format (**ASCII**) :

```
AT+BSSID=[!?][mode],[bssid]<CR>
+OK[=mode,bssid]<CR><LF><CR><LF>
```

- Parameter:

mode: BSSID Mode

Value	Description
0	automatic
1	Designation

bssid: Network BSSID, A hexadecimal number of 12 in the format 001EE3A34455

2.2.2.14 Set/query the specified wireless channel mode : **AT+CHL**

- Function: Set/query the specified wireless channel mode .

- Format (**ASCII**) :

```
AT+CHL=[!?][ mode],[channel]<CR>
+OK[=mode,channel]<CR><LF><CR><LF>
```

- Parameter:

mode: Channel mode

Value	Description
-------	-------------



0	automatic
1	Designation

channel: Wireless channel number , effective range 1~14 .

2.2.2.15 Set / Query SoftAP Wireless Channel Mode : **AT+APCHL**

- Function:

Set / Query SoftAP Wireless Channel Mode .

- Format (**ASCII**) :

```
AT+APCHL=[!?][ mode],[channel]<CR>
+OK[=mode,channel]<CR><LF><CR><LF>
```

- Parameter:

mode: Channel mode

Value	Description
0	automatic
1	Designation

channel: Wireless channel number , effective range 1~14 .

2.2.2.16 Wireless Channel List: **AT+CHLL**

- Function: Set/query the list of wireless channels. The wireless channel list parameter is used to specify the working channel range of the module. Channels not included in the list will not be scanned. Reasonable use of this parameter can speed up the scanning and networking speed of the module.
- Format (**ASCII**) :

```
AT+CHLL=[!?][channel list]<CR>
+OK[=channel list]<CR><LF><CR><LF>
```



- Parameter:

channel list: The list of wireless channels, in hexadecimal format, starting from the lowest bit, each bit representing a channel, the default is 3fff, indicating 1~14 all channels

2.2.2.17 Enable automatic creation of adhoc network functions : **AT+WATC**

- Function:

Set/Query whether to enable the automatic creation of the adhoc network function. This setting is valid only when the wireless network type is set to adhoc, indicating whether an adhoc network with the same name is automatically created when the network join fails.

- Format (**ASCII**) :

```
AT+WATC=[!?][enable]<CR>
+OK[=enable]<CR><LF><CR><LF>
```

- Parameter:

enable: Enable flag

Value	Description
0	Not enabled
1	Enable

2.2.2.18 Turn automatic energy saving mode on/off : **AT+WP**

- Function: Turn automatic energy saving mode on/off

Note:

This power-saving mode is the energy-saving mode of the wifi protocol. It only turns off the wireless transceiver and reduces the CPU frequency. This mode CPU does not sleep, so it can receive AT/RI commands. After the power-saving mode is turned on, the WiFi module enters the WiFi_off state after wireless idle. If there is no



external wake-up, the WiFi is turned on when the time period indicated by the TIM information element of the beacon frame [minimum 100ms] comes, according to the TIM in the Beacon frame. The domain determines whether there is data to be received [including broadcast frames and unicast frames]. If there is no data, it will immediately enter the WiFi_off state. If there is data after processing, the wireless access will enter the WiFi_off state. If there is external wake-up during WiFi_off, it will open. WiFi, until the next wireless idle and then enter the WiFi_off state.

Ways to wake up the module: AT port directly sends data will wake up the module

- Format (**ASCII**) :

```
AT+WPSM=[!?][enable]<CR>
+OK[=enable]<CR><LF><CR><LF>
```

- Parameter:

enable: Enable flag

Value	Dscription
0	Not enabled
1	Enable

- e.g.

Turn on the power save mode (Note: AT+WPSM=1 is valid only after the module joins the hotspot):

```
AT+WPSM=1
```

```
+OK
```

Turn off power save mode :

```
AT+WPSM=0
```

```
+OK
```

2.2.2.19 Enable/disable AP SSID broadcast : **AT+BRDSSID**

- Function:

Enable/disable AP SSID broadcast. This setting is valid only when the module is an AP.

- Format (**ASCII**) :

```
AT+BRDSSID=[!?][enable]<CR>
+OK[=enable]<CR><LF><CR><LF>
```

- Parameter:

enable: Whether to enable SSID broadcast

Value	Description
0	Ban AP SSID broadcast
1	Enable AP SSID broadcast

2.2.2.20 UART port data format : **AT+UART**

- Function: Set/query the uart interface data format.
- Format (**ASCII**) :

```
AT+UART=[!?][baudrate],[databit],[stopbit],[parity],[flowcontrol]<CR>
+OK[=baudrate,databit,stopbit,parity]<CR><LF><CR><LF>
```

- Parameter:

baud rate: Baud rate, RMS range 1200~115200bps

Value	Description
115200	115200 bps
57600	57600 bps



38400	38400 bps
19200	19200 bps
9600	9600 bps
4800	4800 bps
2400	2400 bps
1200	1200 bps

data bit: data bit

Value	Dscription
0	8 bit
1	7 bit

stop bit: Stop bit

Value	Dscription
0	1 bit
1	not support
2	2 bit

parity: parity

Value	Dscription
0	No parity
1	Odd parity
2	Even parity

2.2.2.21 Built-in enable WEB management server : **AT+WEBS**

- Function: Set/Query whether built-in enabled WEB Management Server
- Format (**ASCII**) :

```
AT+WEBS=[!?][enable],[port]<CR>
+OK[=enable,port]<CR><LF><CR><LF>
```

- Parameter:

enable: Enable flag

Value	Description
0	Not enabled
1	enable

port: Server port number, default is 80

2.2.2.22 Device name : **AT+DNAME**

- Function: Set/query the device name.
- Format (**ASCII**) :

```
AT+DNAME=[!?][devicename] <CR>
+OK[=devicename]<CR><LF><CR><LF>
```

- Parameter:

devicename: Device name, 1~32 characters

2.2.2.23 System login password : **AT+PASS**

- Function: Set / query the system login password.
- Format (**ASCII**) :



```
AT+PASS=[!?][pass] <CR>
+OK[=pass]<CR><LF><CR><LF>
```

- Parameter:

pass: 6 ASCII characters

2.2.2.24 Receiving user data : **AT+CUSTDATA**

- Function:

Receive the user data sent by the one-click configuration tool. Send the AT+ONESHOT=1 command before use to configure the module in one-button configuration mode.

- Format:

```
AT+CUSTDATA[=?]<CR>
+OK=data<CR><LF><CR><LF>
```

- Parameter: Null

2.2.2.25 Query the configured networking parameters : **AT+CNTPARAM**

- Function: Query the configured networking parameters.
- Format (**ASCII**) :

```
AT+CNTPARAM[=?]<CR>
+OK=<bssid_en>,[bssid],[ssid],<key><CR><LF><CR><LF>
```

- Parameter: Null

返回值: bssid_en 值的含义



Value	Description
0	BSSID is not enabled
1	Enable BSSID networking

If the BSSID is enabled, it returns 1, bssid, key

If BSSID is not enabled ,returns 0, ssid, key

2.2.3 Network control class

2.2.3.1 NIC interface mode :**AT+PORTM**

- Function: Set/query the interface mode of the Network Card.
- Format (**ASCII**) :

```
AT+PORTM=[!?][mode]<CR>
+OK[=mode]<CR><LF><CR><LF>
```

- Parameter:

mode: Interface mode

Value	Description
0	Low speed UART
1	High speed UART
2	H-SPI
3	H-SDIO

- e.g.:

Query the NIC interface mode:



→	AT+PORTM=?
←	+OK=0

2.2.3.2 Get the IP address of the external domain name : **AT+SKGHBN**

- Function: Obtain the IP of the external domain name.
- Format (**ASCII**) :

```
AT+SKGHBN =[!?][URL] <CR>
+OK[=IP]<CR><LF><CR><LF>
```

- Parameter:
 - URL: External domain name
 - IP: Corresponding IP address
- e.g.: After the network is successfully added, the IP address of the external domain name can be queried as follows. :

→	AT+WJOIN
←	+OK=3c46d82bd81e,0,11,0,"TP-LINK_HyFi_1E",49
→	AT+SKGHBN= <u>www.baidu.com</u>
←	+OK="115.239.211.112"

2.2.3.3 Set / Query WPS Features : **AT+WWPS**

- Function:
 - Set/Query WPS function.
- Format (**ASCII**) :



```
AT+WWPS=[!?][mode],[pin]<CR>
+OK[=mode],[pin]<CR><LF><CR><LF>
```

- Parameter :

mode: WPS function selection, empty parameters do not need to be filled out.

mode	pin	Dscription
get_pin		Get the pin code
set_pin	Pin Code	Set the pin code
start_pin		Start networking
start_pbc		Start networking

pin: PIN code of the wireless router

2.2.3.4 Join the specified AP : **AT+WJOIN**

- Function :

Join/create the specified network depending on the type of network you have set up. If the current network type is STA, this command functions to connect to the AP. If the current network type is SoftAP, this command functions to create a SoftAP. If the current network type is Adhoc, this command function specifies the Adhoc network for the connection, and can choose whether to automatically create the network if the network with the specified SSID is not detected according to the setting parameters. If the current network is already connected or created, return the network connection information directly. For ASCII format, the system returns a response message after the network connection is successful.

- Format (**ASCII**) :

```
AT+WJOIN<CR>
+OK=<bssid>,<type>,<channel>,<encry>,<ssid>,<rssi><CR><LF><CR><LF>
```

- Parameter :

Bssid:Network BSSID,A hexadecimal number of length 12 in the format 001EE3A34455

type: NetworkType



Value	Description
0	STA Mode
1	Adhoc Mode
2	SoftAP Mode
3	APSTA Mode

channel: Channel number

b_encrypt: Encryption mode

Value	Description
0	Open
1	Encryption

SSID: Wireless network name, 1~32 characters, surrounded by double quotes

rsi: Network signal strength, without negative sign, unit Db, ie 50 means signal strength is -50Db

• e.g.:

→	AT+SSID=TP-LINK_HyFi_1E
←	+OK
→	AT+KEY=1,0,""
←	+OK
→	AT+WJOIN
←	+OK=3c46d82bd81e,0,11,0,"TP-LINK_HyFi_1E",53



2.2.3.5 Disconnect the current network : **AT+WLEAV**

- Function :

This command is only valid when the module is acting as a STA and is used to disconnect the current wireless network.

- Format (**ASCII**) :

```
AT+WLEAV<CR>
+OK<CR><LF><CR><LF>
```

- Parameter: Null
- e.g.: Query the connection status after screening, and then query the connection

status after exiting the network. :

->	AT+SSID=TP-LINK_HyFi_1E
←	+OK
→	AT+KEY=1,0,""
←	+OK
->	AT+WJOIN
←	+OK=3c46d82bd81e,0,11,0,"TP-LINK_HyFi_1E",53
→	AT+LKSTT
←	+OK=1,"192.168.1.109","255.255.255.0","192.168.1.1","192.168.1.1","0.0.0.0"
→	AT+WLEAV
←	+OK
→	AT+LKSTT
←	+OK=0

2.2.3.6 Scan wireless network: **AT+WSCAN**

- Function:

This command is valid only when the module is acting as a STA. It is used to scan the wireless network and return after completion.

- Format (**ASCII**) :

```
AT+WSCAN<CR>
+OK=<bssid>,<type>,<channel>,<encry>,<ssid>,<rssi><CR><LF>
    <bssid>,<type>,<channel>,<encry>,<ssid>,<rssi><CR><LF>
.....
<CR><LF>
```

- Parameter:

The same as AT+WJOIN

- e.g.:

→	AT+WSCAN
←	+OK=828917C49D9A,2,1,1,"AirM2M_WiFi",70 C4CAD90B1592,2,1,1,"qianyue-lan",86 68DB540CC142,2,4,1,"O2@PHICOMM",76 64098014661A,2,6,1,"Xiaomi_6619",64 7C11CB04F7B5,2,6,0,"",74 0E5415290C52,2,6,1,"LAPTOP-JNPMKPQP 7565",56 104400631C69,2,6,1,"",84 EC26CAB3094E,2,6,1,"Black Ship Corp",74 7C11CB04F7B4,2,6,1,"HUAWEI-UM57MQ",76 8825930EAEAF,2,6,1,"GST_2.4G",84 0E26CAB3094E,2,6,1,"Doge Smart Office",74 286C0764C470,2,7,1,"FB715",66 2A6C0764C470,2,7,0,"",64 3C46D82BD81E,2,11,0,"TP-LINK_HyFi_1E",60 AC9E176C8AF8,2,10,1,"Finejoint_sec",80



```
789682A20C18,2,11,1,"xiaoman-ZTE-2.4G-A20C18",62
00226C68DDE8,2,11,0,"RT8580_DDE8",78
08107999C460,2,11,1,"Netcore_air",76
A8574ED51AFE,2,12,1,"MEVIUS",82
30FC68606128,2,11,1,"Carebao717",72
```

2.2.3.7 Query the local network connection status : **AT+LKSTT**

- Function: Query the status of the local network connection.
- Format (**ASCII**) :

```
AT+LKSTT<CR>
+OK[=status,ip,netmask,gateway,dns1,dns2]<CR><LF><CR><LF>
```

- Parameter:

status: ConnectionStatus

Value	Description
0	disconnect
1	connection

ip: Ip address, the data format is "192.168.1.22", without quotes

netmask: Subnet mask, data format is the same as ip address

gateway: Gateway address, data format is the same as ip address

dns1: DNS1 address, data format is the same as ip address

dns2: DNS2 address, data format is the same as ip address

- e.g.:

Query the connection status after screening, and then query the connection status after exiting the network. :

```
→ AT+SSID=TP-LINK_HyFi_1E
```



←	+OK
→	AT+KEY=1,0,""
←	+OK
→	AT+WJOIN
←	+OK=3c46d82bd81e,0,11,0,"TP-LINK_HyFi_1E",53
→	AT+LKSTT
←	+OK=1,"192.168.1.109","255.255.255.0","192.168.1.1","192.168.1.1","0.0.0.0"
→	AT+WLEAV
←	+OK
→	AT+LKSTT
←	+OK=0

2.2.3.8 Set / Query SoftAP Status : **AT+APLKSTT**

- Function :

Set/query SoftAP wireless channel status, valid only in SoftAP and APSTA modes.

- Format :

```
AT+APLKSTT<CR>
+OK[=status,ip,netmask,gateway,dns1,dns2]<CR><LF><CR><LF>
```

- Parameter :

status : Connection Status

Value	Description
0	disconnection



1	connection
---	------------

ip: Ip address, the data format is "192.168.1.22", without quotes

netmask: Subnet mask, data format is the same as ip address

gateway: Gateway address, data format is the same as ip address

dns1: DNS1 address, data format is the same as ip address

dns2: DNS2 address, data format is the same as ip address

- e.g.:

The module acts as a SoftAP, the phone joins the AP, and then queries the module status:

→	AT+WPRT=!2
←	+OK
→	AT+APSSID=!Luat_TEST_AP
←	+OK
→	AT+APENCRY=!1
←	+OK
→	AT+APKEY=!1,1,"12345"
←	+OK
→	AT+APNIP=1,192.168.1.1,255.255.255.0,192.168.1.1,192.168.1.1
←	+OK
→	AT+WJOIN
←	+OK=2a6dcd004e7d,2,11,1,"Luat_TEST_AP",30
→	AT+APLKSTT



←	+OK=1,"192.168.1.1","255.255.255.0","192.168.1.1","192.168.1.1","0.0.0.0"
---	---

9. Query the connected station : **AT+SLIST**

- Function :

Query the station that is connected.

- Format :

AT+SLIST<CR>
+OK[=sta_number,sta_mac1,sta_ip1,sta_mac2,sta_ip2...]<CR><LF><CR><LF>

- Parameter :

sta_number: Number of stations that have been connected

sta_mac: mac address of station

sta_ip: ip address of station

- e.g.:

Follow the example in [Setting/Querying SoftAP Status: AT+APLKSTT](#). Query AT+SLIST before any mobile phone joins the hot spot Luat_TEST_AP:

→	AT+SLIST
←	+OK=0

Then, the phone joins Luat_TEST_AP and queries AT+SLIST:

→	AT+SLIST
←	+OK=1,,94-FE-22-9A-B5-28,192.168.1.2

2.2.3.10 Build a socket connection : **AT+SKCT**

- Function :



Create a socket. In client mode, it returns after waiting for the connection to complete (success or failure); in server mode, it returns directly after the creation is completed.

- Format (**ASCII**) :

```
AT+SKCT=[protocol],[cs],[host_timeout],<remote_port>,<local_port><CR>
+OK=<socket><CR><LF><CR><LF>
```

- Parameter:

protocol: protocol type

Value	Description
0	TCP
1	UDP

cs: C/S mode,

Value	Description
0	Client
1	Server

host_timeout: According to protocol and cs, the descriptions are as follows

cs	protocol	Description
0	X	Destination server name, you can enter the domain name or ip address, such as "192.168.1.100" or "www.sina.com.cn"
1	0	The TCP connection timeout period, that is, the client connected to the server is automatically kicked off after sending no data at this time. The valid value range is 1~10000000, the unit is seconds, 0 means never, the default is 120 seconds.
1	1	Meaningless

remote_port: Remote port number



local_port: Local port number

socket: socket number

- e.g.:

→	AT+SKCT=0,0,180.97.81.180,51950,37189
←	+OK=1

1 is socket id

2.2.3.11 Send data through the specified socket : **AT+SKSND**

- Function:

Send data through the specified socket and return when finished. This command sends data in binary format and the user should start sending the raw data after receiving the response message (+OK) from the module. After the module receives the specified length of data, it automatically ends the data transmission phase and sends the data to the network. The excess data will be discarded. Otherwise, after waiting for the timeout (1s), the module forces the end of the data transfer phase and sends the received data to the network.

- Format (ASCII) :

```
AT+SKSND=<socket>,<size><CR>
+OK=<actualsize><CR><LF><CR><LF>
[data steam]
```

- Parameter:

- e.g.:

socket: socket number

size: The length of the data to be sent, bytes

actualsize: The length of data allowed to be sent, bytes

data steam: Raw data



→	AT+SKSND=1,5
←	+OK=1
→	abcde

2.2.3.12 Read the data in the receive buffer of the specified socket : **AT+SKRCV**

- Function :

Reads the data in the receive buffer of the specified socket and returns after completion. After receiving this command, the module will transfer the specified length data in binary format after sending the corresponding message (+OK).

- Format (**ASCII**) :

```
AT+SKRCV=<socket>,<maxsize><CR>
+OK=<size><CR><LF><CR><LF>
[data steam]
```

- Parameter :

- e.g.:

Socket: socket number

Maxsize: the maximum data length that can be received

Size: the actual length of the received data

Data steam: raw data

→	AT+SKRCV=2,20
←	+OK=17
←	HELLO WIFI MODULE

2.2.3.13 Get the specified socket state : **AT+SKSTT**

- Function:

Gets the specified socket state. The first line of the return value indicates the status information of the socket specified by the user. If the socket type is a TCP server, each line from the next line indicates the socket state of an accessed client.

- Format (**ASCII**) :

```
AT+SKSTT=<socket><CR>
+OK=<socket>,<status>,[host],[HostPort],[LocalPort],[rx_data]<CR><LF>
[socket],[status],[host],[HostPort],[ LocalPort],[rx_data]<CR><LF>
...
<CR><LF>
```

- Parameter:

socket:socket number

status:socket status

Value	Dscription
0	disconnect
1	monitor
2	connect

host: 对端ip 地址

HostPort: counterpart port number

LocalPort: Local port number

rx_data: Data length in the receive buffer

- e.g.:

→	AT+SKSTT=1
←	+OK=1,2,"36.7.87.100",6100,59749,0

2.2.3.14 Close the specified socket : **AT+SKCLS**

- Function :

Close the specified socket.

- Format (**ASCII**) :

```
AT+SKCLS=<socket><CR>
+OK<CR><LF><CR><LF>
```

- Parameter :

socket: socket number

- e.g.:

→	AT+SKCLS=1
←	+OK

2.2.3.15 Set the socket sent by the system by default: **AT+SKSDF**

- Function :

Set the socket that the system sends by default. When the user needs to enter the transparent transmission mode in the command mode, use this command to specify the destination for sending transparent data of the serial port.

- Format (**ASCII**) :

```
AT+SKSDF=<socket><CR>
+OK<CR><LF><CR><LF>
```

- Parameter :



socket: socket number

- e.g.: Please refer to [Serial port enters transparent transmission mode: AT+ENTM](#) demo

2.2.3.16 Get the source IP address of the current socket received data : **AT+SKSRCIP**

- Function:

Get the source IP address of the current socket received data.

- Format (**ASCII**) :

```
AT+SKSRCIP=?<CR>
+OK=[host]<CR><LF><CR><LF>
```

- Parameter:

Host: Source IP address of the data

- e.g.:

→	AT+SKSRCIP=?
←	+OK=36.7.87.106

2.2.3.17 Socket actively reports receiving data : **AT+SKRPTM**

- Function:

Turn the socket on and off to actively report the receive data function.

- Format (**ASCII**) :

```
AT+SKRPTM=<mode><CR>
+OK<CR><LF><CR><LF>
```

- Parameter:



Mode :

Value	Dscription
0	Close
1	Open

- e.g.:

→	AT+ SKRPTM=1
←	+OK

2.2.3.18 One-click configuration : **AT+ONESHOT**

- Function: Turns the one-click configuration feature on or off.
- Format (ASCII) :

```
AT+ONESHOT=<status><CR>
+OK<CR><LF><CR><LF>
```

- Parameter:

status:

Value	Dscription
0	close
1	open

- e.g.:

	Connect the mobile phone WIFI to the target router A, and then open the one-key configuration function , as follows:
--	--



→	AT+ONESHOT=1
←	+OK
	Then the mobile phone opens the one-click configuration APP, enters the user name and password of the router A in the APP, and then, enters the one-click configuration process.
	After the one-click configuration is successful, the APP will prompt, the mobile phone will automatically exit the one-click configuration function at this time, or you can manually exit, as follows :
→	AT+ONESHOT=0
←	+OK

2.2.3.19 HTTP client post get function : **AT+HTTPC**

- Function:

Http client post get function.

- Format (**ASCII**) :

```
AT+HTTPC=<url>,<verb>,<postdata><CR>
+OK<CR><LF><CR><LF>
```

- Parameter:

url: Remote http server address ;

verb:

Value	Dscription
0	http get
1	-
2	http post
3	http put

post data: When verb is 2 or 3, it is used to upload data for http.

Note: You need to open the socket active reporting function AT+SKRPTM=1 before using the httpc command.



2.2.4 MQTT Instruction

2.2.4.1 Set up the MQTT server : **AT+MSERVER**

- Function: Set the MQTT server IP address and port.
- Format (**ASCII**) :

```
AT+MSERVER=<port>,<ipaddr><CR>
+OK<CR><LF><CR><LF>
```

- Parameter:

<port>: MQTT server port number, without double quotes

<ipaddr>: MQTT server IP address (Do not support domain name address), do not need to add double quotes

2.2.4.2 Set login account and password : **AT+MLOGIN**

- Function: Set the MQTT username and password.
- Format (**ASCII**) :

```
AT+MLOGIN=<user>,<password><CR>
+OK<CR><LF><CR><LF>
```

- Parameter:

<user>: Username, no double quotes

<password>: Password, no double quotes

2.2.4.3 Set client id: **AT+MID**

- Function: Set the client id of the MQTT.
- Format (**ASCII**) :



```
AT+MID=<client_id><CR>
+OK<CR><LF><CR><LF>
```

- Parameter:

<client_id>: client id, no need to add double quotes

2.2.4.4 Connect to the MQTT server : **AT+MCONNECT**

- Function: Connect to the MQTT server.
- Format (**ASCII**) :

```
AT+MCONNECT<CR>
+OK<CR><LF><CR><LF>

Success: +MQTT:CONNECTED <CR><LF><CR><LF>
Failure: +MQTT:FAIL<CR><LF><CR><LF>
```

- Parameter:

Null

2.2.4.5 Subscribe to a topic : **AT+MSUB**

- Function: Subscribe to a topic.
- Format (**ASCII**) :

```
AT+MSUB=<topics>,<qos><CR>
+OK<CR><LF><CR><LF>

Success : +MSUB:OK
Failure : +MSUB:<result>
```

- Parameter:

<result>:Result Code



2.2.4.6 Post a message : **AT+MPUB**

- Function: Post a message.
- Format (**ASCII**) :

```
AT+MPUB=<topics>,<qos>,<retatin>,<mssage><CR>
```

```
+OK<CR><LF><CR><LF>
```

```
Success: +MPUB:OK
```

```
Failure: +MPUB:<result>
```

- Parameter:

<result>:Result Code

2.2.4.7 Received a message : **AT+MTOPIC,AT+MQD**

- Function: Received a message.
- Format (**ASCII**) :

```
+MTOPIC:<topiclcn>,<topic>
```

```
+MQD:<len>,<data>
```

- Parameter:

<topiclcn>: Subject length

<topic>: Subject content

<len>: Length of message content

<data>: Message content

2.2.4.8 Shut down the MQTT server : **AT+MCLOSE**

- Function: Shut down the MQTT server.



- Format (ASCII) :

```
AT+MCLOSE<CR>
+OK<CR><LF><CR><LF>
```

- Parameter

Null

2.2.4.9 MQTT Result Code

Result Code	Definition
0	everything OK
-1	Out of memory error
-2	Buffer error
-3	Timeout
-4	Routing problem
-5	Operation in progress
-6	Illegal value
-7	Operation would block
-8	Address in use
-9	Already connecting
-10	Connection already established
-11	Not connected
-12	Low-level netif error
-13	Connection aborted
-14	Connection reset
-15	Connection closed



-16	Illegal argument
-----	------------------

10. MQTT usage example

Note: Currently, the MQTT server address in the MSERVER command does not support domain names at present, only IP addresses are supported.

→	AT+WPRT=0
←	+OK
→	AT+SSID=TP-LINK_HyFi_1E
←	+OK
→	AT+KEY=1,0,""
←	+OK
→	AT+WJOIN
←	+OK=3c46d82bd81e,0,11,0,"TP-LINK_HyFi_1E",53
→	AT+LKSTT
←	+OK=1,"192.168.1.109","255.255.255.0","192.168.1.1","192.168.1.1","0.0.0.0"
→	AT+MSERVER=1883,120.55.137.106
←	+OK
→	AT+MLOGIN=user,password
←	+OK
→	AT+MID=TEST_MQTT
←	+OK
→	AT+MCONNECT



←	+OK +MQTT:CONNECTED	
→	AT+MSUB=HELLO_WORLD	
←	+OK	
→	AT+MPUB=Fred,0,0,888AAA	
←	+OK +MPUB:OK	
←	+MTOPIC:11, HELLO_WORLD +MQD:10,12345_test	Note: Received an MQTT message
→	AT+MCLOSE	
←	+OK	



3 Common operation

3.1 Create a SoftAP process

- (1) **WPRT** sets the wireless network card working mode to SoftAP:

```
AT+WPRT=2
```

- (2) **APSSID** Set the AP SSID for the STA to MyAP:

```
AT+APSSID=MyAp
```

- (3) **APENCRY** Set the wireless network card security mode to WEP64:

```
AT+APENCRY=1
```

Parameter: open: 0, WEP64: 1, WEP128: 2

- (4) **APKEY** Set the wireless network card key to 12345

```
AT+APKEY=1,1,12345
```

Parameter1: Key format, 0 means HEX, 1 means ASCII

Parameter2: index: Key index number, 1 to 4 are used for WEP encryption keys, and other encryption methods are fixed to 0.

Parameter 3: wireless key, e.g.: 12345

- (5) **APNIP** Set the ip address and subnet mask

```
AT+APNIP=1,192.168.1.1,255.255.255.0,192.168.1.1,192.168.1.1
```

Parameter 1: address type, 0 means dynamic allocation using DHCP, 1 means static address

parameter2: ip:192.168.1.1

parameter3: netmask: 255.255.255.0

parameter4: gateway: 192.168.1.1

parameter5: dns: 192.168.1.1



- (6) **PMTF** saves the above parameters to spi flash, just start from step 7 with the next boot.

AT+PMTF

- (7) **WJOIN** Create wireless network **MyAp**

AT+WJOIN

- (8) **SLIST** Query the STA information which connected to your SoftAP.

AT+SLIST

3.2 Scan AP Process

Wireless network card scanning AP's AT command is :

AT+WSCAN

3.3 STA joins the AP process

- (1) **WPRT** Set the working mode to STA

AT+WPRT=0

- (2) **SSID** Set the AP name to join. e.g. TEST_AP

AT+SSID=TEST_AP

- (3) **KEY** Set the wireless key of the AP you want to join. e.g. 12345678

AT+KEY=1,0,12345678

parameter1: , 0 means HEX, 1 means ASCII

parameter2: index: The key index number, 1 to 4, is used for the WEP encryption key. The other encryption methods are fixed to 0.

parameter3: Wireless key e.g.: 12345678

- (4) **NIP** Enable DHCP

AT+NIP=0



- (5) **PMTF** Save the above parameters to spi flash , Just start from step 6 with the next boot

AT+PMTF

- (6) **WJOIN** Join the wireless network TEST_AP

AT+WJOIN

3.4 Create an APSTA process

- (1) **WPRT** Set the working mode to APSTA

AT+WPRT=3

- (2) **SSID** Set the AP name to be joined, such as TEST_AP

AT+SSID=TEST_AP

- (3) **KEY** Set the wireless key of the AP you want to join. e.g.

12345678 AT+KEY=1,0,12345678

parameter1: , 0 means HEX, 1 means ASCII

parameter2: index: The key index number, 1 to 4, is used for the WEP encryption key. The other encryption methods are fixed to 0.

parameter3: Wireless key e.g.: 12345678

- (4) **APSSID** Set the network name of the created SOFTAP

AT+APSSID="MYSoftAP"

- (5) **APENCRY** Set the encryption type of SoftAP (such as WPA2-TKIP)

AT+APENCRY=5

- (6) **APKEY** Set the password for SoftAP (e.g. ASCII code 87654321)

AT+APKEY=1,0,87654321

- (7) **APNIP** Set the IP address and subnet mask

AT+APNIP=1,192.168.1.1,255.255.255.0,192.168.1.1,192.168.1.1



- (8) **PMTF** Save the above parameters to spi flash, just start from step 9

AT+PMTF

- (9) **WJOIN** Join the wireless network TEST_AP

AT+WJOIN

5. How the STA disconnects the AP

The wireless network card disconnects the AP's AT command:

AT+WLEAV

6. SoftAP disconnected

The AT command of SoftAP disconnected network is:

AT+WLEAV=2

3.7 How STA view current status

The AT command for the wireless network card to view the status of the current network card is:

AT+LKSTT

3.8 View current SoftAP status

The AT command to view the current SoftAP status is:

AT+APLKSTT

3.9 How to use the socket function

- (1) Create a TCP server on the PC side. For example, if you use the TCP debugging assistant, the TCP server address is 192.168.1.100 and the listening port is 1000.



(2) Create a Socket:

TX: AT+SKCT=0,0,192.168.1.100,1000,1000

RX: +OK=1 ---> 1 is the socket number

Note: Before sending SKCT, please ensure that the module is connected to a WIFI hotspot with an INTERNET connection.

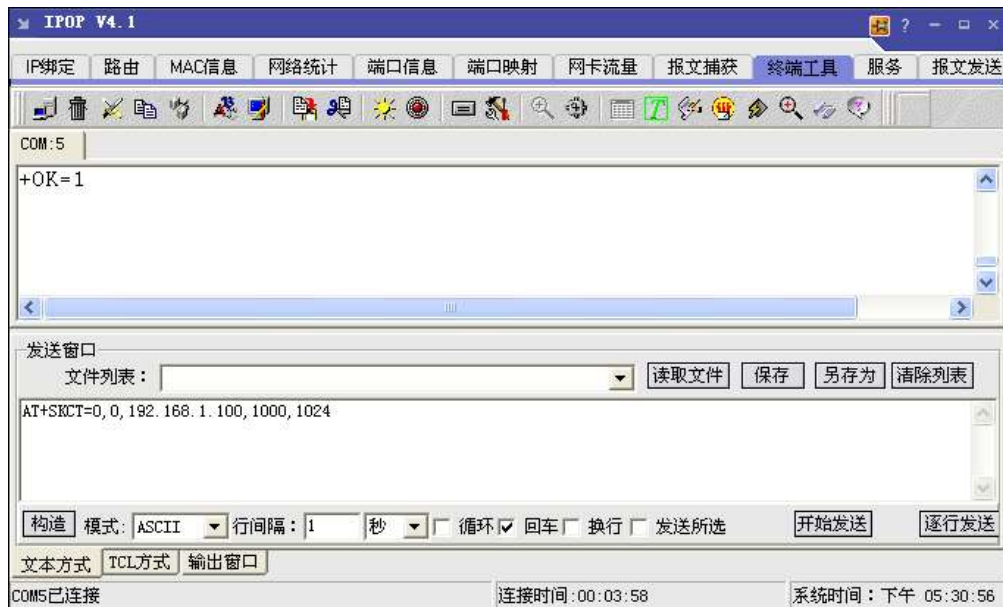

(3) send data :

TX: AT+SKSND=1,5

kevin

RX: +OK=5

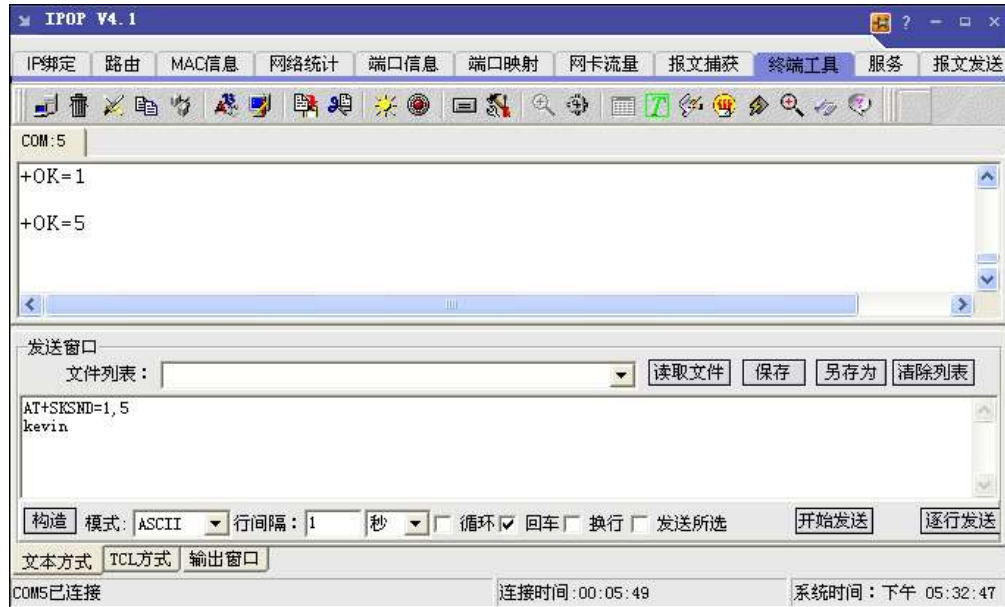

TCP server Received the data interface as :



(4) Receive data:

Enter hello on the TCP Debugging Assistant interface and click Send



TX: AT+SKRCV=1,5

RX: +OK=5

hello

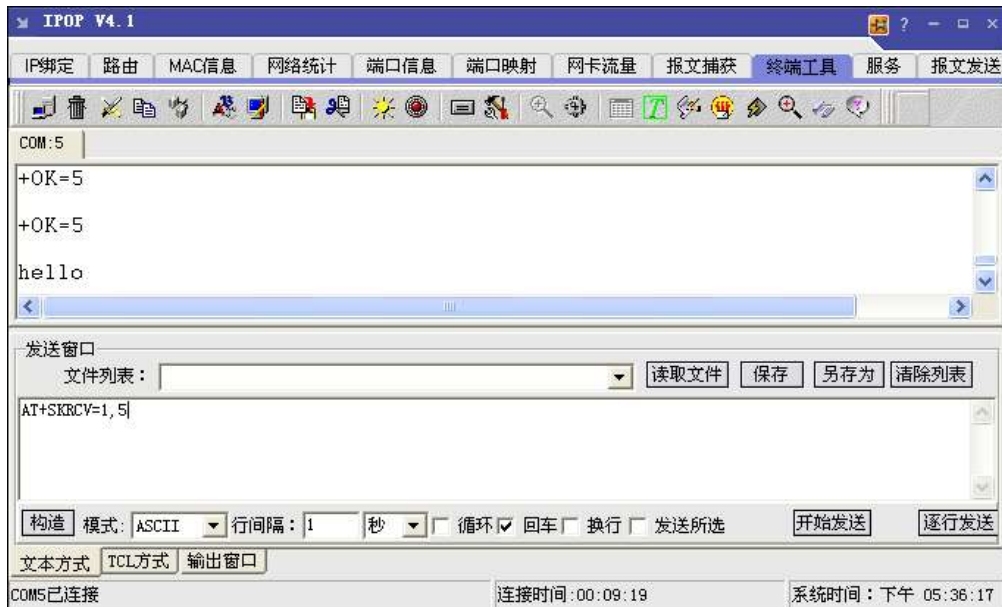

(5) 查询Socket 状态:

TX: AT+SKSTT=1

RX: +OK=1,2,"192.168.1.100",1000,1024,0



(6) Close Socket connection

TX: AT+SKCLS=1 RX: +OK





3.10 Transparent transmission application in automatic working mode

(1) **WPRT** sets the wireless network card working mode to STA AT+WPRT=0

(2) **SSID** Set the name of the AP you want to join, such as airm2m_wifi

```
AT+SSID=airm2m_wifi
```

(3) **KEY** Set the wireless key of the AP you want to join, for example 12345678

```
AT+KEY=1,0,12345678
```

(4) **NIP** Enable DHCP

```
AT+NIP=0
```

(5) **ATM** Set to automatic working mode

```
AT+ATM=0
```

(6) **ATRM** Set the socket connection in automatic working mode

```
AT+ATRM=0,0,192.168.1.100,1000
```

(7) **PMTF** Save parameters to spi flash

```
AT+PMTF
```

(8) **Z** Reset the wireless network card to make the configuration take effect

```
AT+Z
```

After reset, the module automatically establishes a socket connection set by ATRM. If you use the process interrupt chain, it will automatically reconnect.